

EE 330

Lecture 24

- Small Signal Models
- Small Signal Analysis

Fall 2024 Exam Schedule

Exam 1	Friday	Sept 27
Exam 2	Friday	October 25
Exam 3	Friday	Nov 22
Final Exam	Monday	Dec 16 12:00 - 2:00
PM		

Dependent Sources

What is a dependent source?

Will you suddenly find dependent sources after you graduate ?

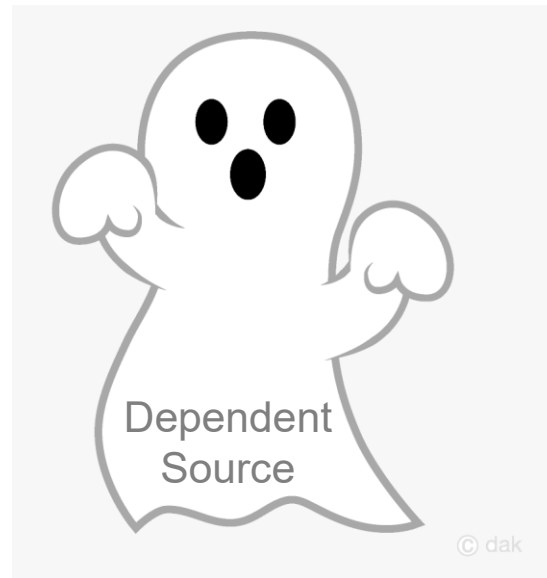

Do dependent sources really exist ?

Why do we place so much emphasis on dependent sources in EE 201?

Amplifier

From Wikipedia: (March 2022)

An **amplifier**, **electronic amplifier** or (informally) **amp** is an electronic device that can increase the power of a signal (a time-varying voltage or current).

An amplifier is another name for any for the four basic dependent sources that are discussed in basic circuits textbooks.

Consider the following MOSFET and BJT Circuits

BJT

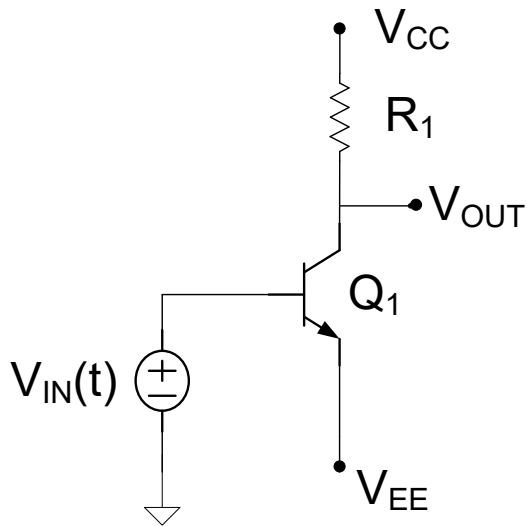

MOSFET

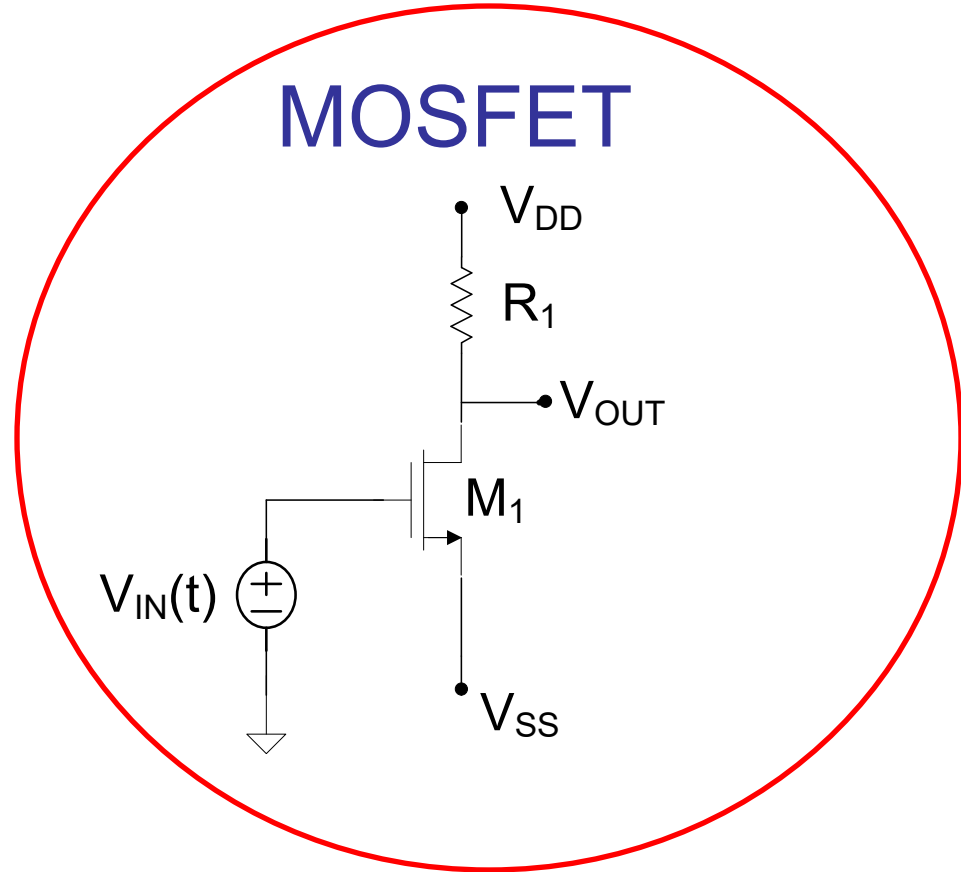

One of the most widely used amplifier architectures

Small signal analysis example

Assume M_1 operating in saturation region

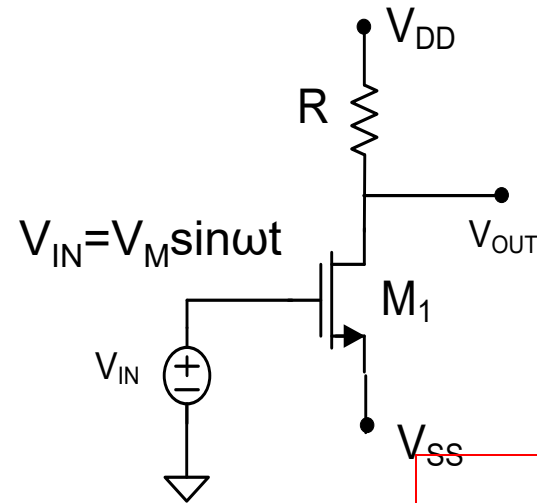

$$V_{OUT} \cong \left\{ V_{DD} - \frac{\mu C_{OX} W}{2L} [V_{SS} + V_T]^2 R \right\} + \left\{ \frac{\mu C_{OX} W}{L} [V_{SS} + V_T] R \right\} V_M \sin \omega t$$

Quiescent Output *ss Voltage Gain*

$$A_v = \frac{\mu C_{OX} W}{L} [V_{SS} + V_T] R$$

$$V_{OUTQ} = \left\{ V_{DD} - \frac{\mu C_{OX} W}{2L} [V_{SS} + V_T]^2 R \right\}$$

$$V_{OUT} \cong V_{OUTQ} + A_v V_M \sin \omega t$$

Total Slides: 80

Note the ss voltage gain is negative since $V_{SS} + V_T < 0!$

Small signal analysis example

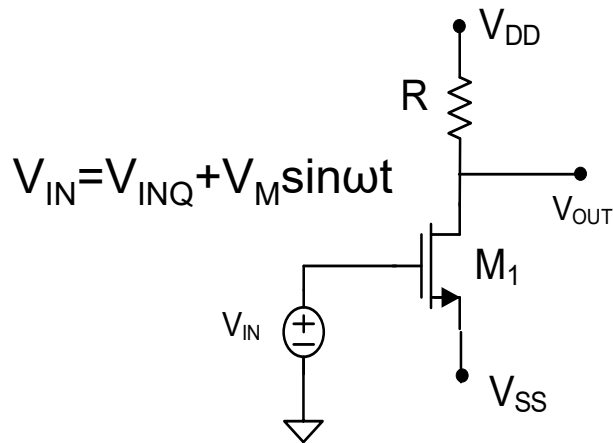

$$A_v = - \frac{2I_{DQ} R}{[V_{GSQ} - V_T]}$$

- Small signal voltage gain is twice the Quiescent voltage across R divided by $V_{GSQ} - V_T$
- Making $I_{DQ}R$ too big or too small will limit signal swing (cause M_1 to leave saturation region)
- Can make $|A_v|$ large by making $V_{GSQ} - V_T$ small
- A_v increases proportionally to the power dissipation (from supply) for fixed V_{GSQ}
- This analysis which required linearization of a nonlinear output voltage is quite tedious.
- This approach becomes unwieldy for even slightly more complicated circuits
- A much easier approach based upon the development of small signal models will provide the same results, provide more insight into both analysis and design, and result in a dramatic reduction in computational requirements

Consider the following MOSFET and BJT Circuits

BJT

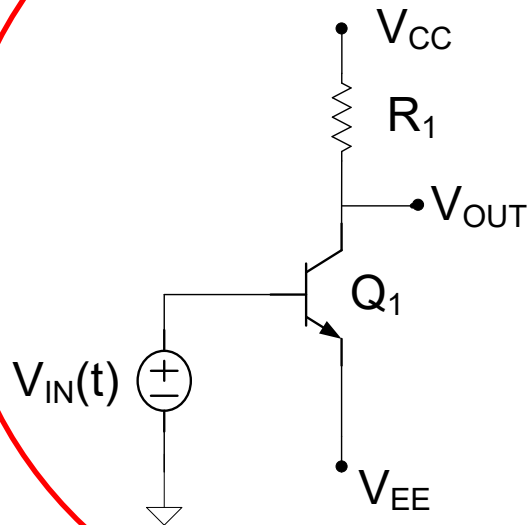

MOSFET

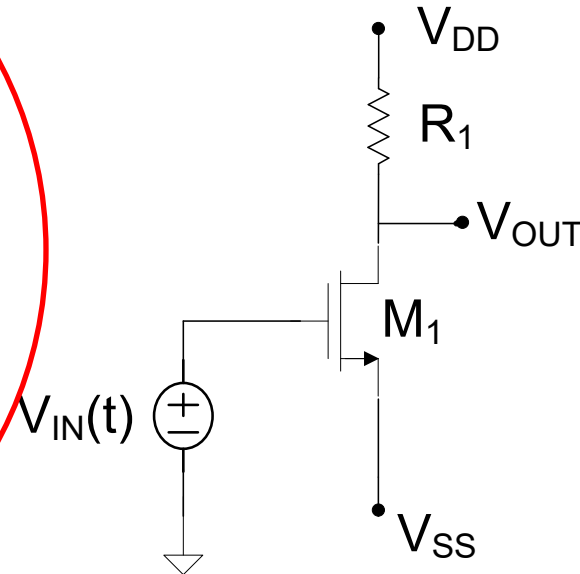

One of the most widely used amplifier architectures

Total Slides: 80

Small signal analysis using nonlinear models

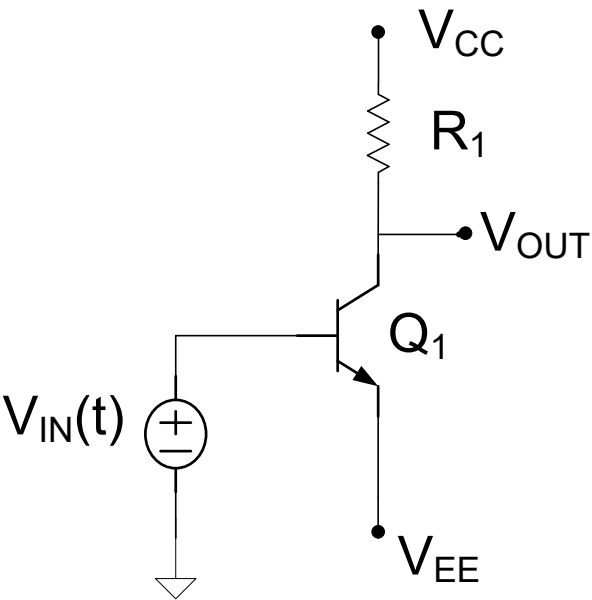

$$V_{IN} = V_{INQ} + V_M \sin \omega t$$

V_M is small

By selecting appropriate value of V_{SS} , M_1 will operate in the forward active region

Assume Q_1 operating in forward active region

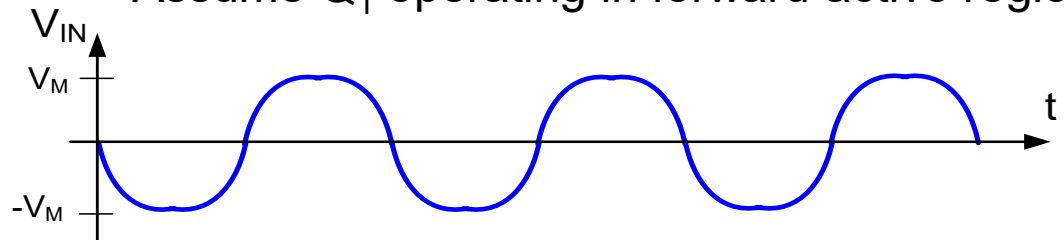

$$V_{OUT} = V_{CC} - I_C R_1$$

$$I_C = J_S A_E e^{\frac{V_{IN} - V_{EE}}{V_t}}$$

$$I_{CQ} = J_S A_E e^{\frac{V_{INQ} - V_{EE}}{V_t}} = J_S A_E e^{\frac{V_{beQ}}{V_t}}$$

$$V_{OUT} = V_{CC} - J_S A_E R_1 e^{\frac{V_{IN} - V_{EE}}{V_t}}$$

$$V_{OUT} = V_{CC} - J_S A_E R_1 e^{\frac{V_M \sin(\omega t) + V_{beQ}}{V_t}}$$

$$V_{OUTQ} = V_{CC} - J_S A_E R_1 e^{\frac{V_{beQ}}{V_t}}$$

Small signal analysis using nonlinear models

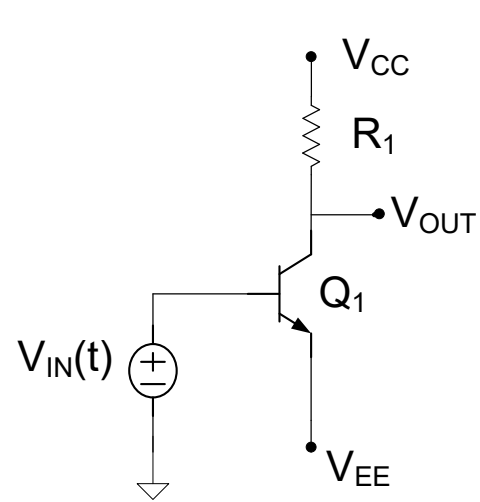

$$I_{CQ} = J_S A_E e^{\frac{V_{beQ}}{V_t}}$$

$$V_{OUT} = V_{CC} - J_S A_E R_1 e^{\frac{V_M \sin(\omega t) + V_{beQ}}{V_t}}$$

$$V_{OUT} = V_{CC} - J_S A_E R_1 e^{\frac{V_{beQ}}{V_t}} e^{\frac{V_M \sin(\omega t)}{V_t}}$$

Recall that if x is small $e^x \cong 1 + x$ (truncated Taylor's series)

$$V_{IN} = V_{INQ} + V_M \sin \omega t$$

V_M is small

$$\therefore V_{OUT} \cong V_{CC} - J_S A_E R_1 e^{\frac{V_{beQ}}{V_t}} \left(1 + \frac{V_M \sin(\omega t)}{V_t} \right)$$

$$V_{OUT} \cong \left[V_{CC} - J_S A_E R_1 e^{\frac{V_{beQ}}{V_t}} \right] - \frac{J_S A_E R_1 e^{\frac{V_{beQ}}{V_t}}}{V_t} V_M \sin(\omega t)$$

Small signal analysis using nonlinear models

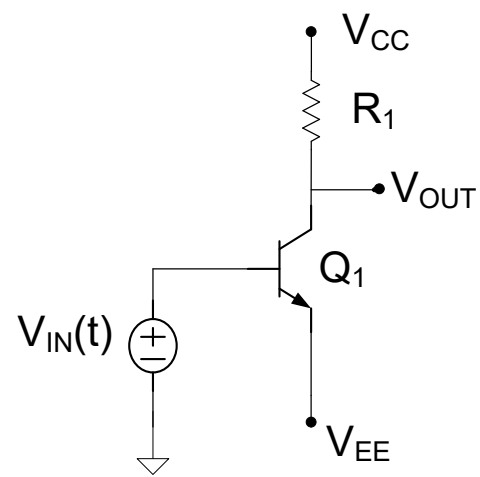

$$I_{CQ} = J_S A_E e^{\frac{V_{beQ}}{V_t}}$$

$$V_{OUT} \cong \left[V_{CC} - J_S A_E R_1 e^{\frac{V_{beQ}}{V_t}} \right] - \frac{J_S A_E R_1 e^{\frac{V_{beQ}}{V_t}}}{V_t} V_M \sin(\omega t)$$

$$V_{IN} = V_{INQ} + V_M \sin \omega t$$

V_M is small

$$V_{OUT} \cong \left[V_{CC} - I_{CQ} R_1 \right] - \left(\frac{I_{CQ} R_1}{V_t} \right) V_M \sin(\omega t)$$

ss Voltage Gain

Comparison of Gains for MOSFET and BJT Circuits

BJT

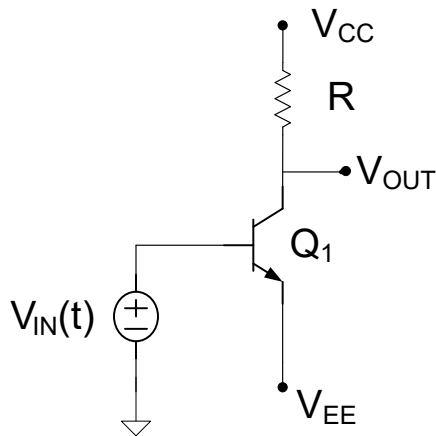

$$A_{VB} = -\frac{I_{CQ} R}{V_t}$$

If $I_{DQ}R_1 = I_{CQ}R = 2V$, $V_{GSQ} - V_T = 1V$, $V_t = 25mV$

$$A_{VB} = -\frac{I_{CQ} R}{V_t} = -\frac{2V}{25mV} = -80$$

MOSFET

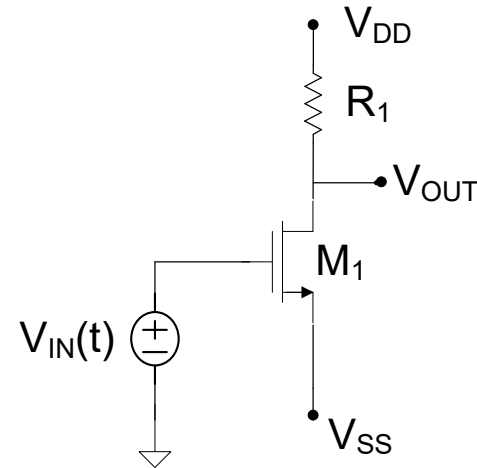

$$A_{VM} = -\frac{2I_{DQ} R_1}{V_{GSQ} - V_T}$$

$$A_{VM} = -\frac{2I_{DQ} R_1}{V_{GSQ} - V_T} = -\frac{4V}{1V} = -4$$

Observe $A_{VB} \gg A_{VM}$

Due to exponential-law rather than square-law model

Total Slides: 80

Operation with Small-Signal Inputs

- Analysis procedure for these simple circuits was very tedious
- This approach will be unmanageable for even modestly more complicated circuits
- **Faster analysis method is needed !**

Small-Signal Analysis

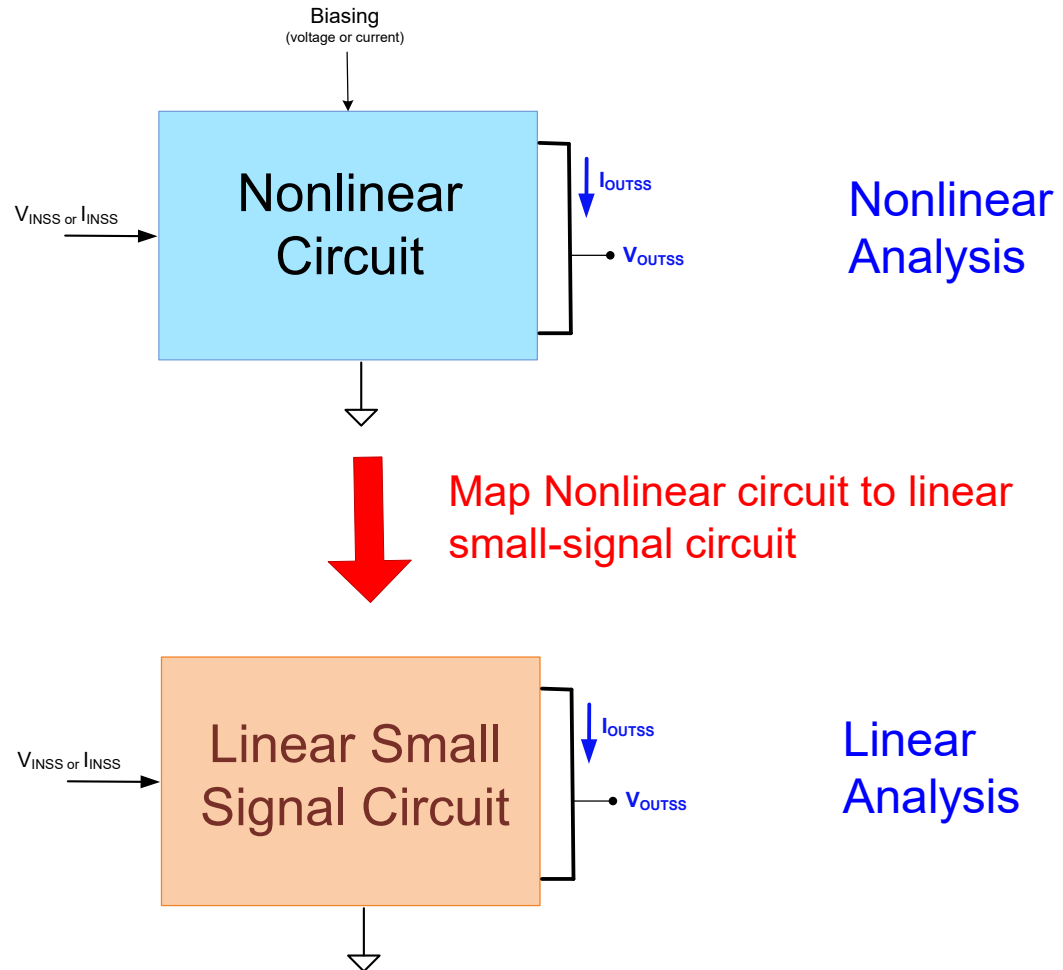

- Will commit next several lectures to developing this approach
- Analysis will be MUCH simpler, faster, and provide significantly more insight
- Applicable to many fields of engineering

Small-Signal Analysis

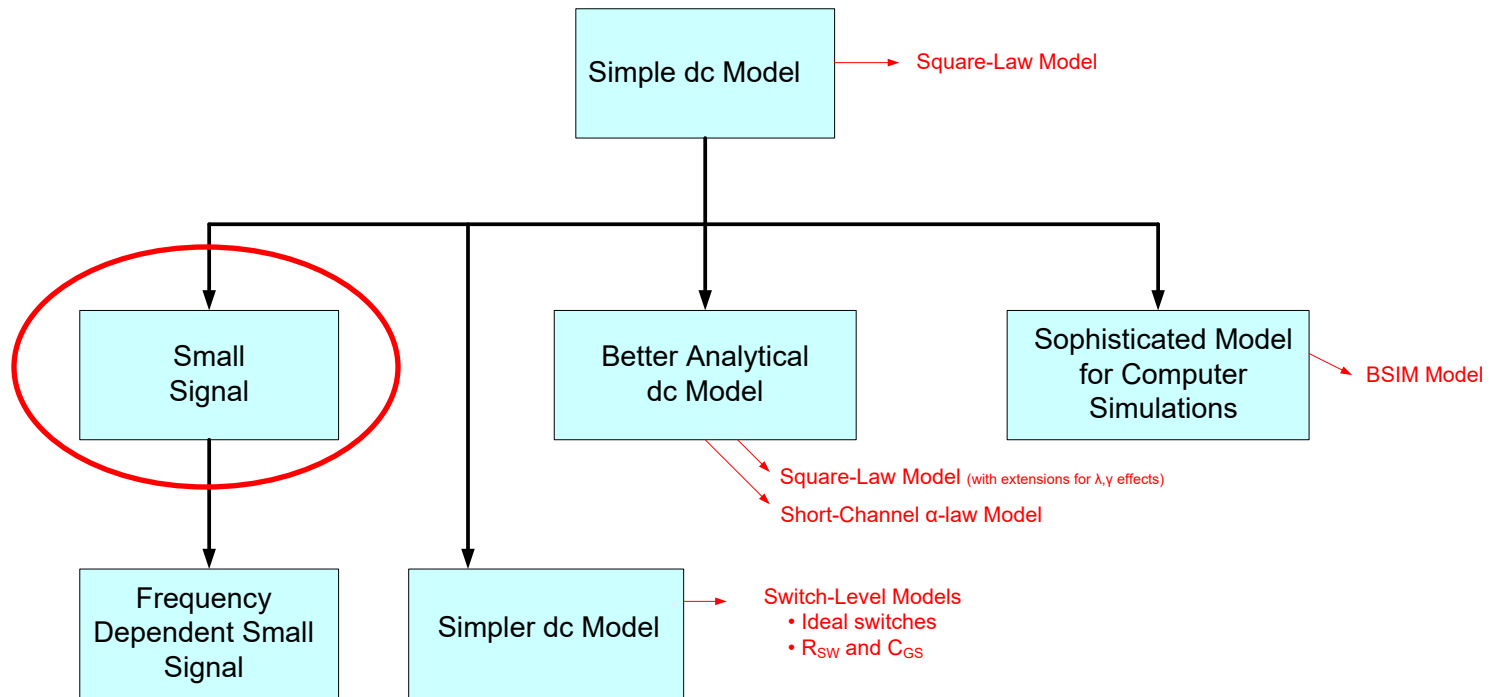

Operation with Small-Signal Inputs

Why was this analysis so tedious?

Because of the nonlinearity in the device models

What was the key technique in the analysis that was used to obtain a simple expression for the output (and that linearly related the output to the input)?

$$V_{\text{OUT}} = V_{\text{CC}} - J_{\text{S}} A_{\text{E}} R_1 e^{\frac{V_{\text{beQ}}}{V_t}} e^{\frac{V_{\text{M}} \sin(\omega t)}{V_t}}$$

$$V_{\text{OUT}} \cong \left[V_{\text{CC}} - I_{\text{CQ}} R_1 \right] - \left(\frac{I_{\text{CQ}} R_1}{V_t} \right) V_{\text{M}} \sin(\omega t)$$

Linearization of the nonlinear output expression at the operating point

Operation with Small-Signal Inputs

$$I_{CQ} = J_S A_E e^{\frac{V_{beQ}}{V_t}}$$

$$V_{OUT} \cong \underbrace{\left[V_{CC} - I_{CQ} R_1 \right]}_{\text{Quiescent Output}} - \underbrace{\left(\frac{I_{CQ} R_1}{V_t} \right)}_{\text{ss Voltage Gain}} V_M \sin(\omega t)$$

Small-signal analysis strategy

1. Obtain Quiescent Output (Q-point)
2. Linearize circuit at Q-point instead of linearize the nonlinear solution (this will be done by linearizing each component in the circuit)
 1. Analyze linear “small-signal” circuit
 2. Add quiescent and small-signal outputs to obtain good approximation to actual output

Small-Signal Principle

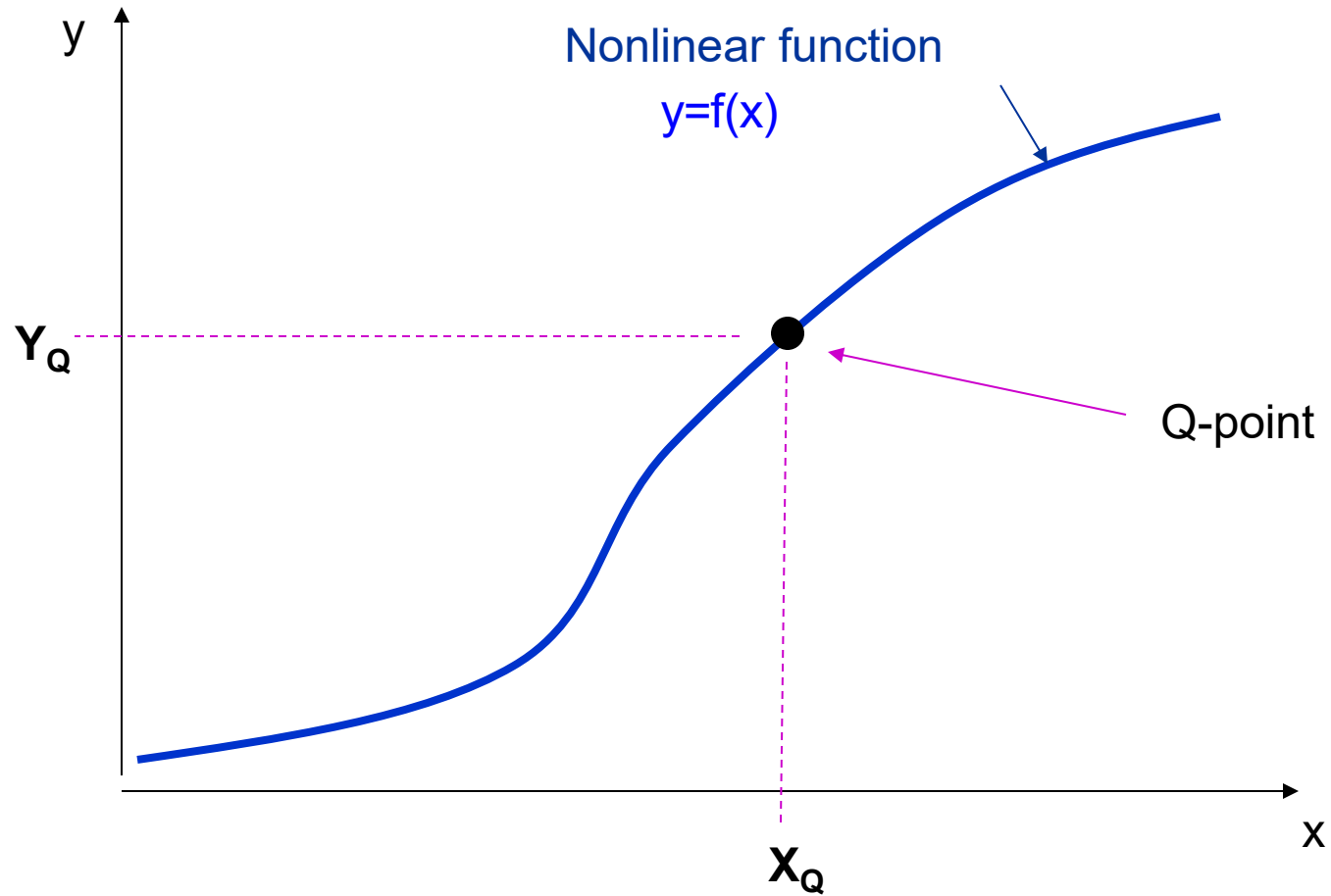

Small-Signal Principle

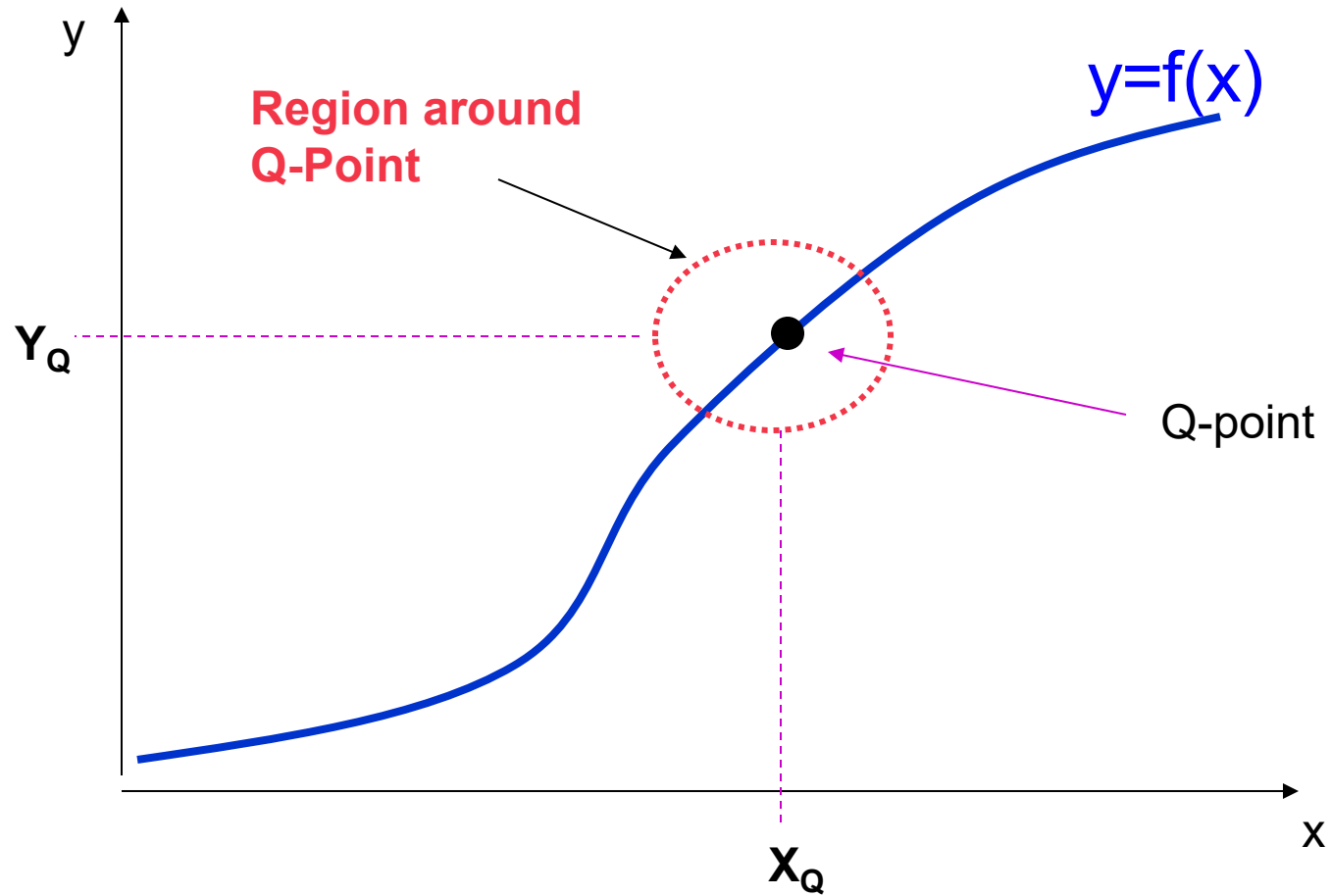

Small-Signal Principle

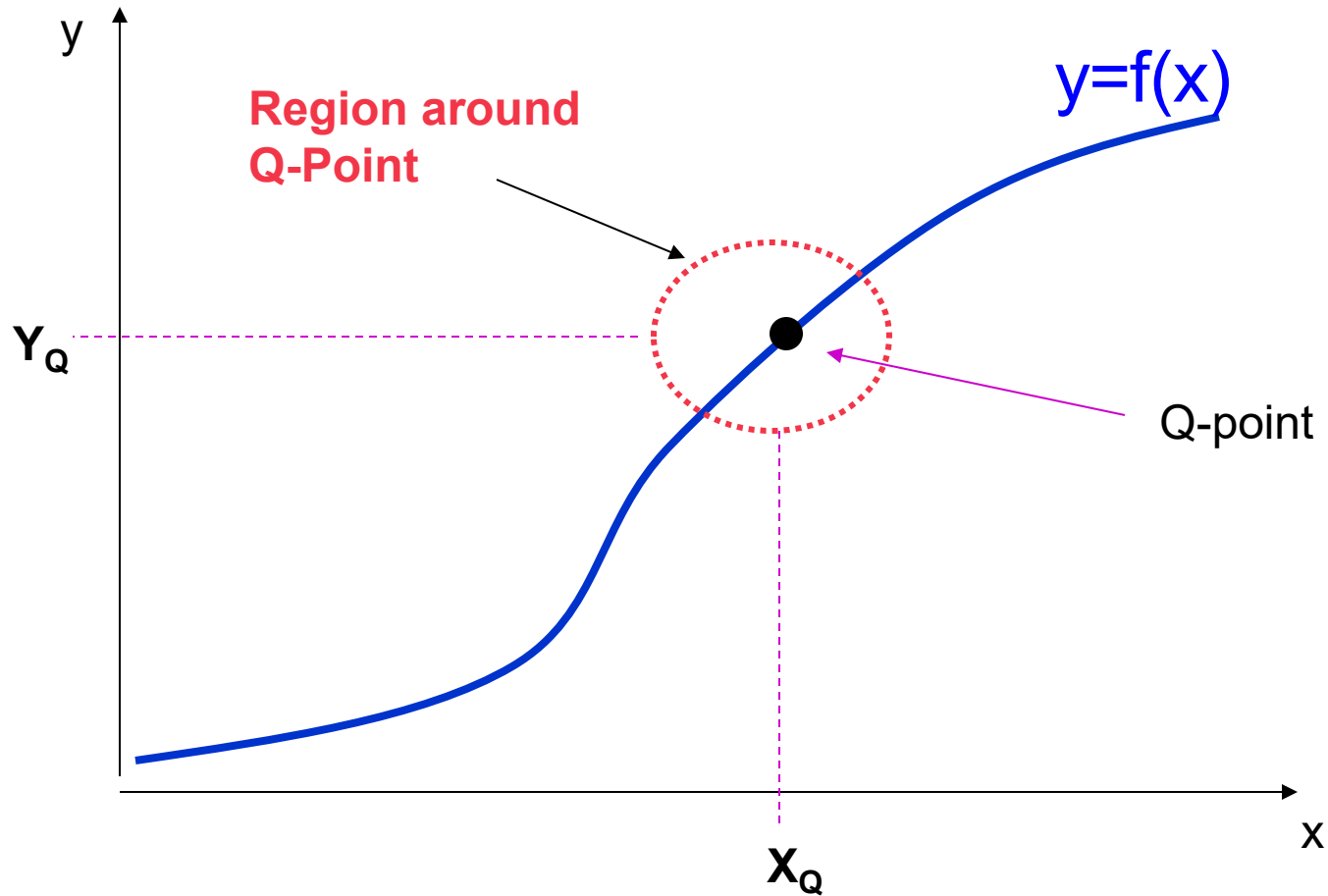

Relationship is nearly linear in a small enough region around Q-point

Region of linearity is often quite large

Linear relationship may be different for different Q-points

Small-Signal Principle

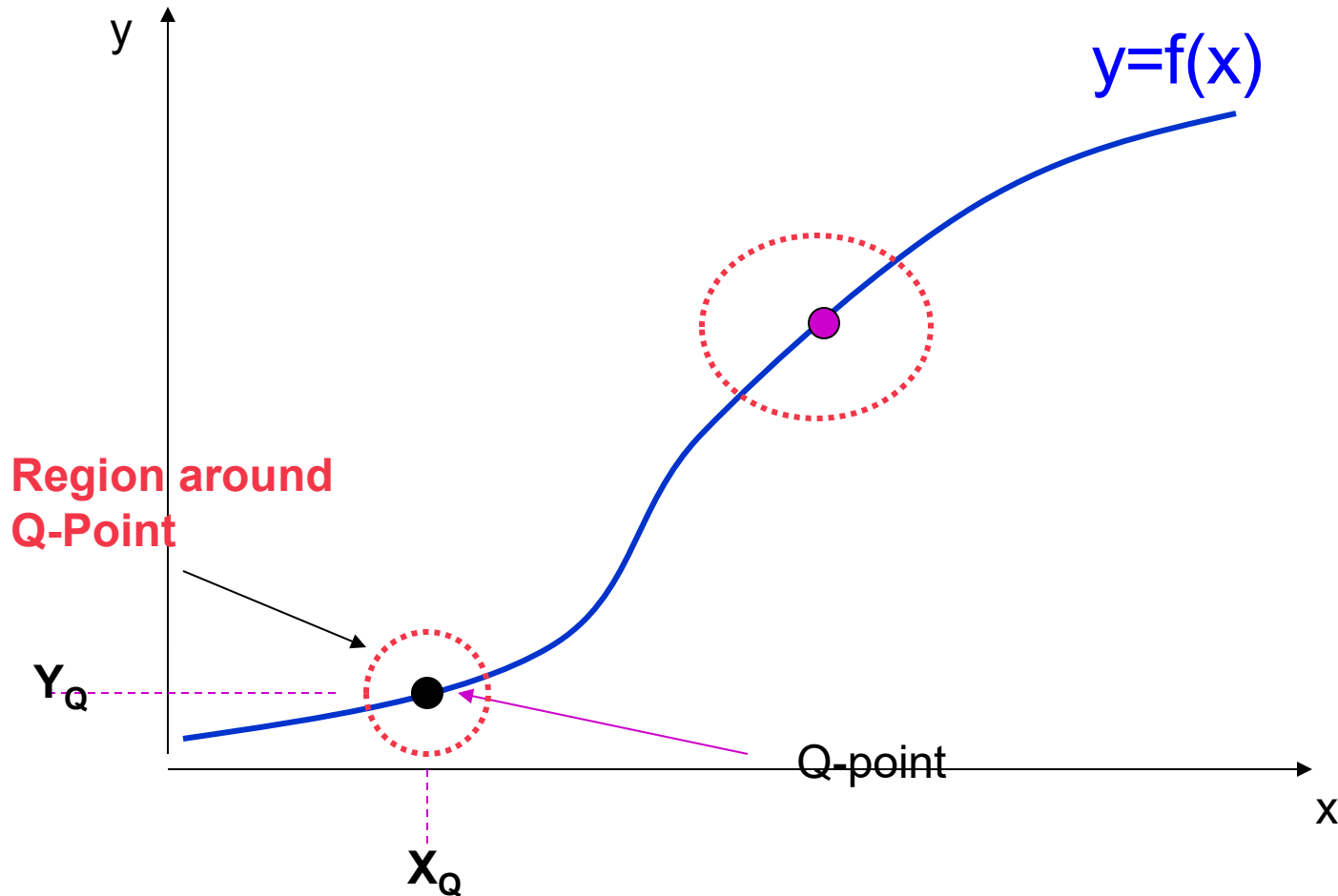

Relationship is nearly linear in a small enough region around Q-point

Region of linearity is often quite large

Linear relationship may be different for different Q-points

Small-Signal Principle

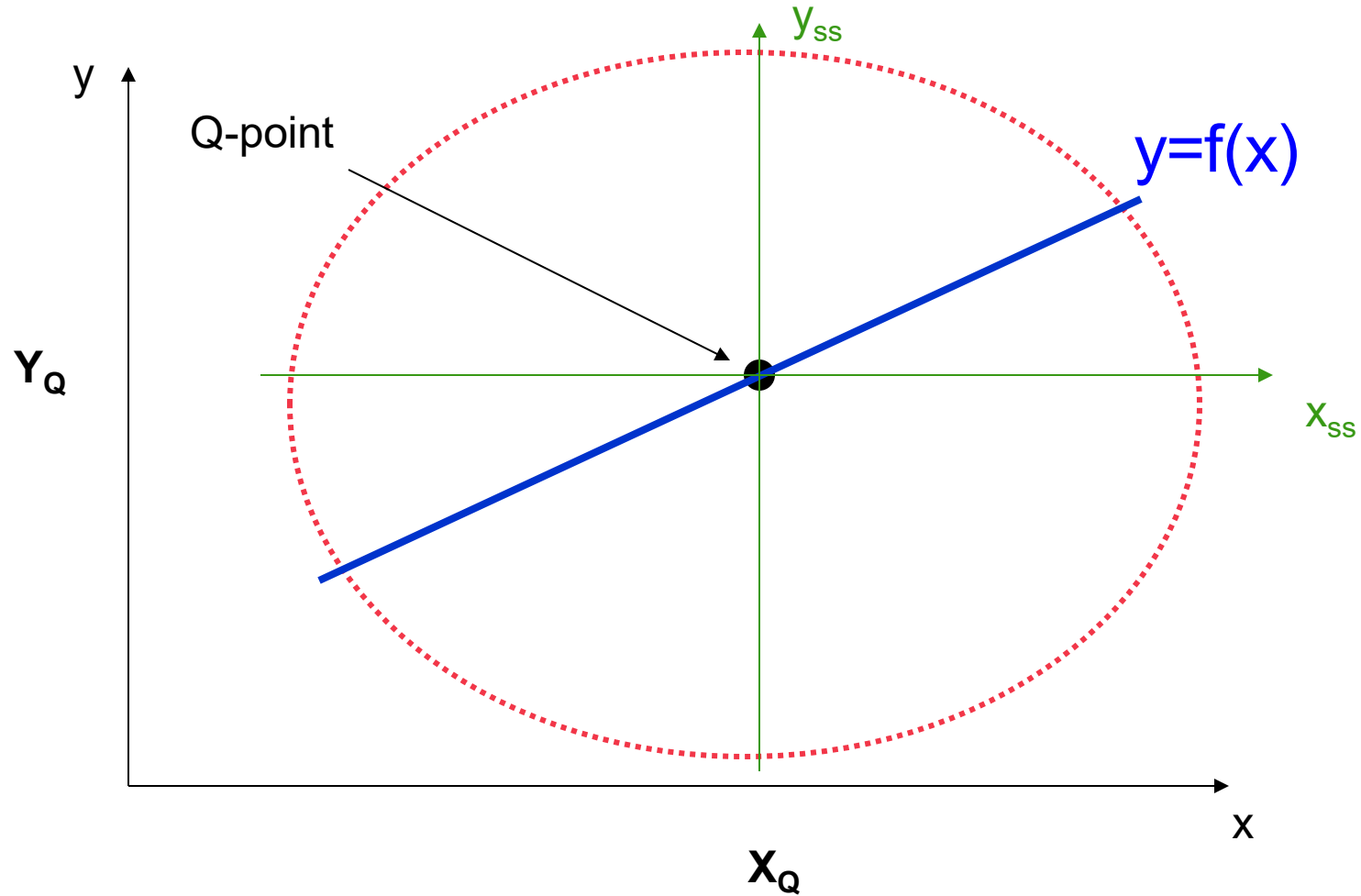

Device Behaves Linearly in Neighborhood of Q-Point
Can be characterized in terms of a small-signal coordinate system²³

Small-Signal Principle

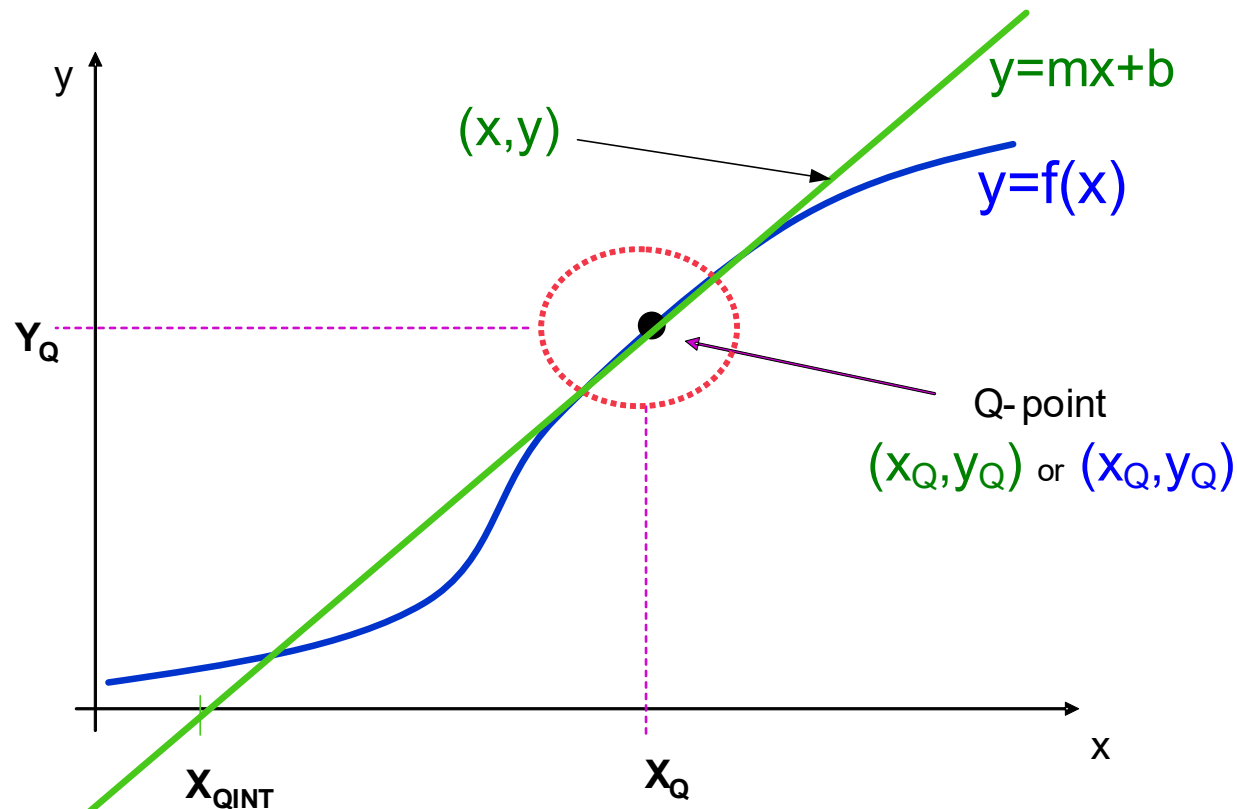

$$\frac{y - y_Q}{x - x_Q} = \left. \frac{\partial f}{\partial x} \right|_{x=x_Q}$$



$$y - y_Q = \left. \frac{\partial f}{\partial x} \right|_{x=x_Q} (x - x_Q)$$

$$y = \left[\left. \frac{\partial f}{\partial x} \right|_{x=x_Q} \right] x + \left[y_Q - x_Q \left. \frac{\partial f}{\partial x} \right|_{x=x_Q} \right]$$

$$m = \left[\left. \frac{\partial f}{\partial x} \right|_{x=x_Q} \right]$$

$$b = \left[y_Q - x_Q \left. \frac{\partial f}{\partial x} \right|_{x=x_Q} \right]$$

Small-Signal Principle

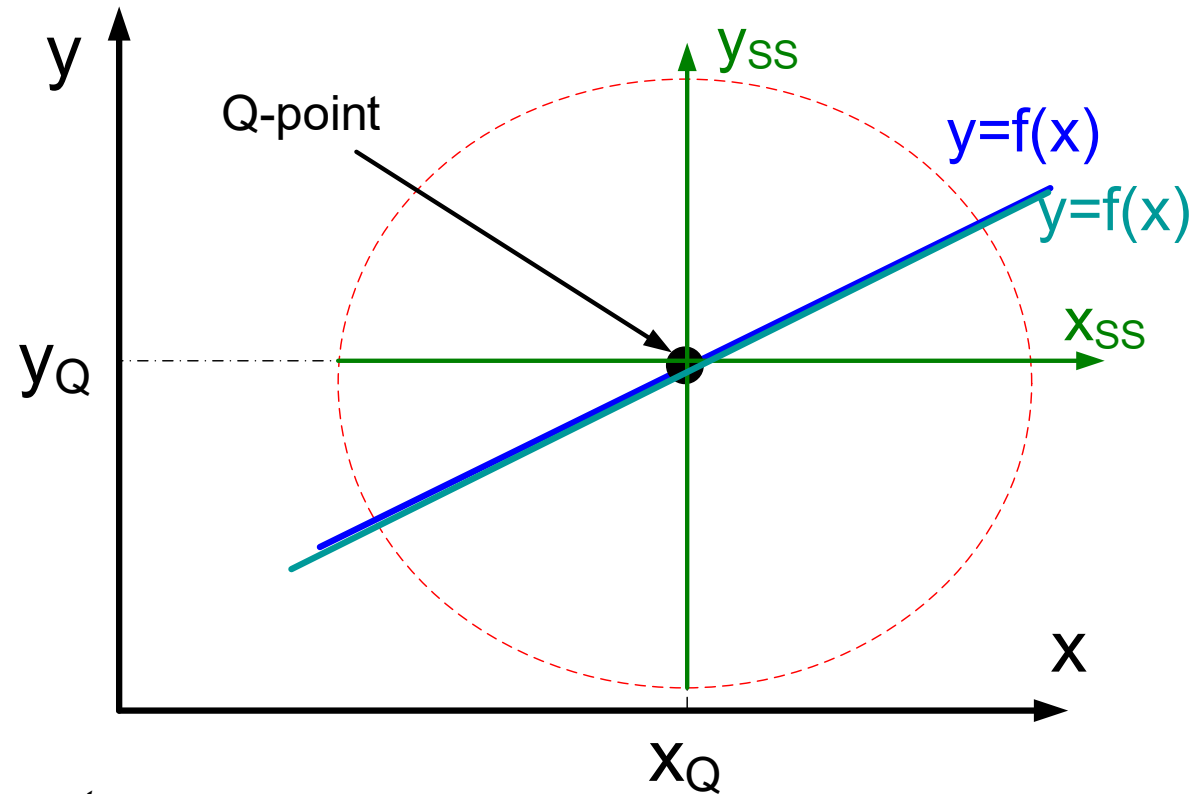

Changing coordinate systems:

$$\begin{aligned} y_{SS} &= y - y_Q \\ x_{SS} &= x - x_Q \end{aligned} \quad y - y_Q = \left. \frac{\partial f}{\partial x} \right|_{x=x_Q} (x - x_Q) \longrightarrow y_{SS} = \left. \frac{\partial f}{\partial x} \right|_{x=x_Q} x_{SS}$$

Small-Signal Principle

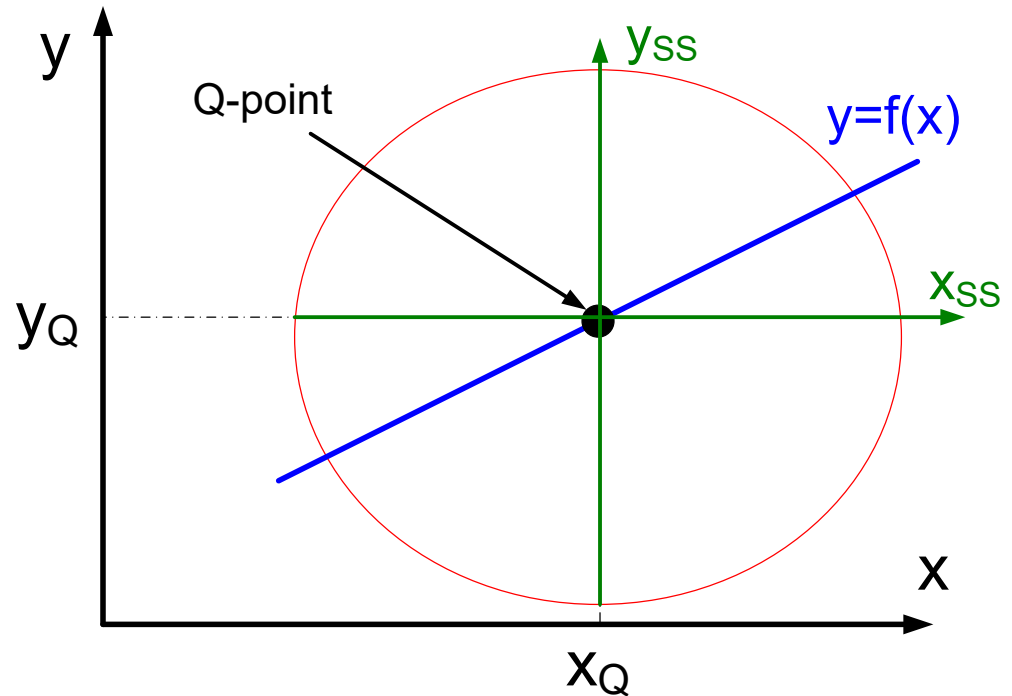

Small-Signal Model:

$$y_{ss} = \left. \frac{\partial f}{\partial x} \right|_{x=x_Q} x_{ss}$$

- Linearized model for the nonlinear function $y=f(x)$
- Valid in the region of the Q-point
- Will show the small signal model is simply Taylor's series expansion of $f(x)$ at the Q-point truncated after first-order terms

Small-Signal Principle

Observe: $y=f(x)$

$$y - y_Q = \left. \frac{\partial f}{\partial x} \right|_{x=x_Q} (x - x_Q) \longrightarrow y_{ss} = \left. \frac{\partial f}{\partial x} \right|_{x=x_Q} x_{ss}$$

$$y_Q = f(x_Q)$$

$$y = f(x_Q) + \left. \frac{\partial f}{\partial x} \right|_{x=x_Q} (x - x_Q)$$

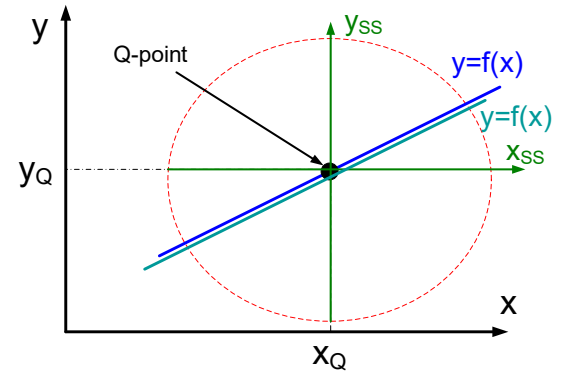

Recall Taylor's Series Expansion of nonlinear function f at expansion point x_0

$$y = f(x_0) + \sum_{k=1}^{\infty} \left(\frac{1}{k!} \left. \frac{df}{dx} \right|_{x=x_0} (x-x_0)^k \right)$$

Truncating after first-order terms (and defining "o" as "Q")

$$y \cong f(x_Q) + \left. \frac{\partial f}{\partial x} \right|_{x=x_Q} (x - x_Q)$$

Small-Signal Model:

$$y_{ss} = \left. \frac{\partial f}{\partial x} \right|_{x=x_Q} x_{ss}$$

Mathematically, linearized model is simply Taylor's series expansion of the nonlinear function f at the Q-point truncated after first-order terms with notation $x_Q=x_0$

Small-Signal Principle

$$y = \boxed{f(x_Q)} + \boxed{\left. \frac{\partial f}{\partial x} \right|_{x=x_Q}} x_{ss}$$

Quiescent Output

ss Gain

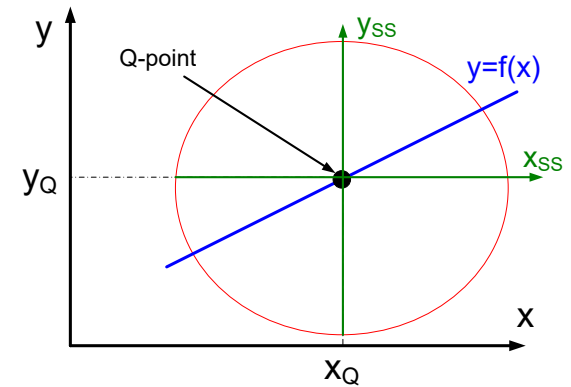

How can a **circuit** be linearized at an operating point as an alternative to linearizing a nonlinear function at an operating point?

Consider arbitrary nonlinear one-port network

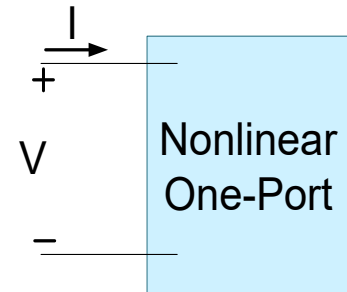

Arbitrary Nonlinear One-Port

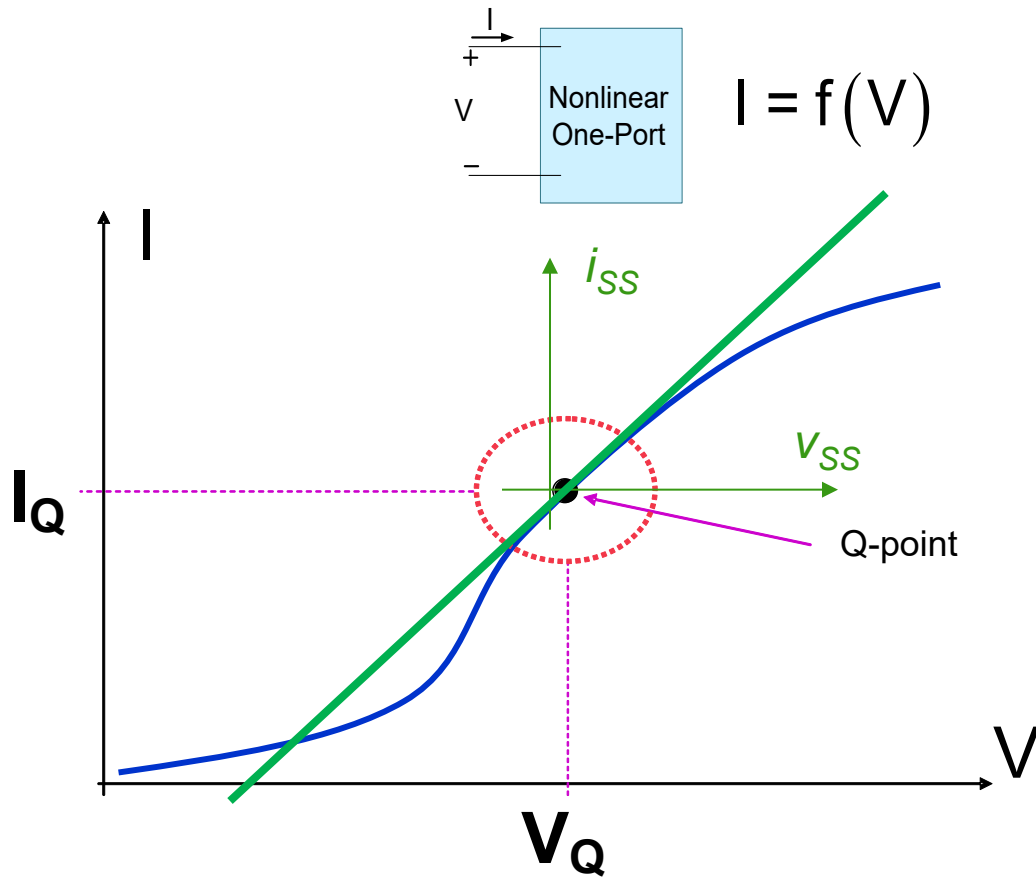

$$i_{ss} = \left. \frac{\partial I}{\partial V} \right|_{V=V_Q} v_{ss}$$

$$\stackrel{\text{def}}{=} i$$

$$\stackrel{\text{def}}{=} v$$

$$y = \left. \frac{\partial I}{\partial V} \right|_{V=V_Q}$$

$$i = y v$$

Linear model of the nonlinear device at the Q-point

Arbitrary Nonlinear One-Port

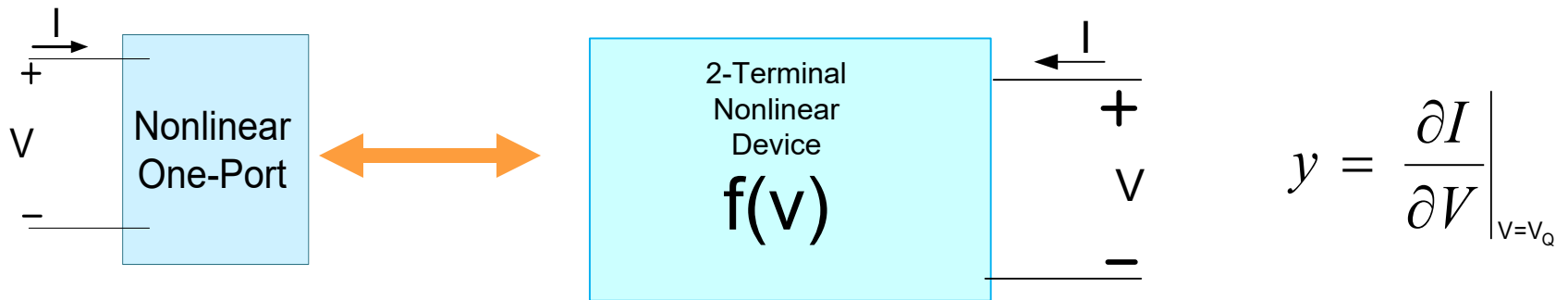

Linear small-signal model:

$$\mathbf{i} = \mathbf{y} \mathbf{v}$$

A Small Signal Equivalent Circuit:

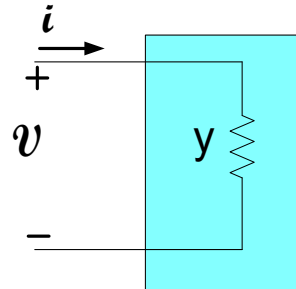

- *The small-signal model of this 2-terminal electrical network is a resistor of value $1/y$ or a conductor of value y*
- ***One small-signal parameter** characterizes this one-port but it is dependent on Q-point*
- *This applies to **ANY** nonlinear one-port that is differentiable at a Q-point (e.g. a diode)*

Small-Signal Principle

Goal with small signal model is to predict performance of circuit or device in the vicinity of an operating point (Q-point)

Will be extended to functions of two and three variables (e.g. BJTs and MOSFETs)

Solution for the example of the previous lecture was based upon solving the nonlinear circuit for V_{OUT} and then linearizing the solution by doing a Taylor's series expansion

- Solution of nonlinear equations very involved with two or more nonlinear devices*
- Taylor's series linearization can get very tedious if multiple nonlinear devices are present*

Natural approach to small-signal analysis of nonlinear networks

- 1. Solve nonlinear network*
- 2. Linearize solution*

Alternative Approach to small-signal analysis of nonlinear networks

- 1. Linearize nonlinear devices (all)*
- 2. Obtain small-signal model from linearized device models*
- 3. Replace all devices with small-signal equivalent*
- 4. Solve linear small-signal network*

“Alternative” Approach to small-signal analysis of nonlinear networks

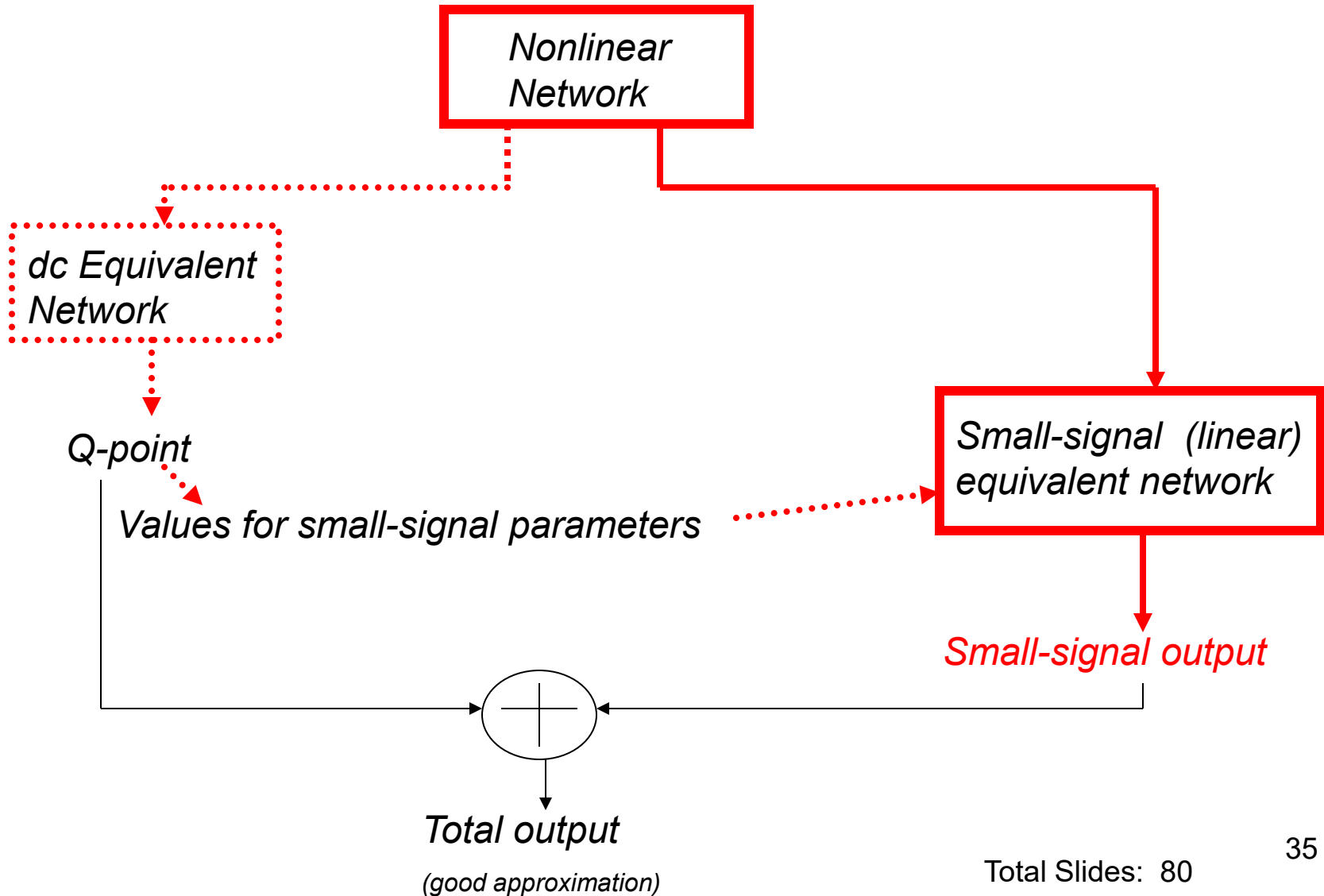

Linearized nonlinear devices

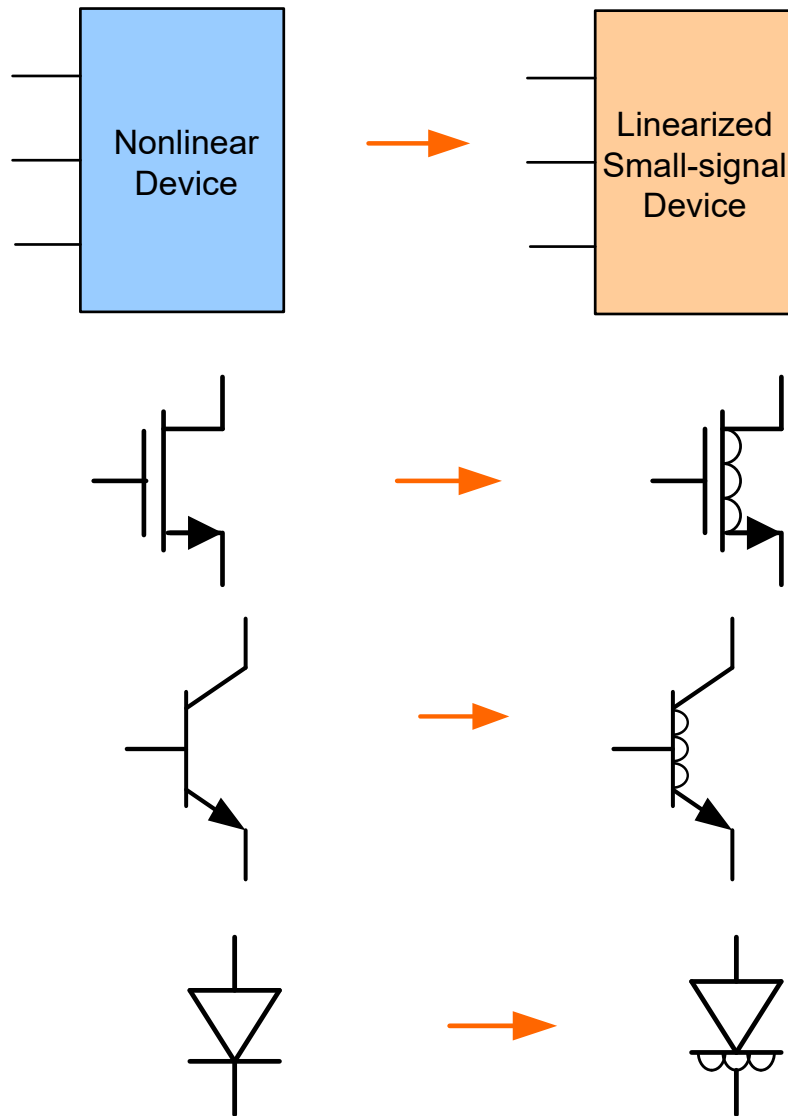

This terminology will be used in THIS course to emphasize difference between nonlinear model and linearized small signal model

Example:

It will be shown that the nonlinear circuit has the linearized small-signal network given

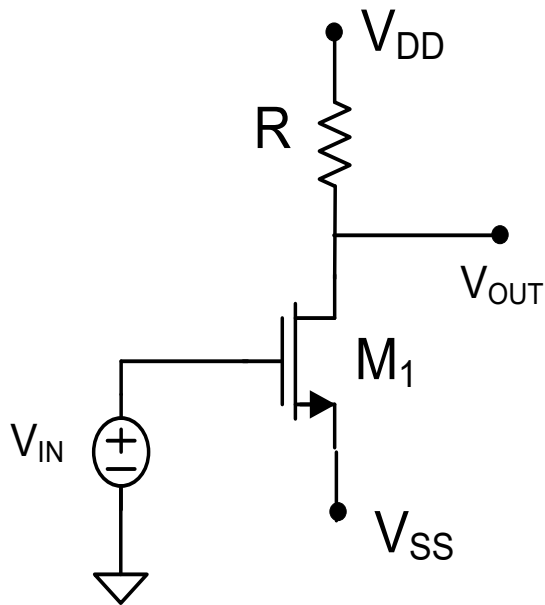

Nonlinear network

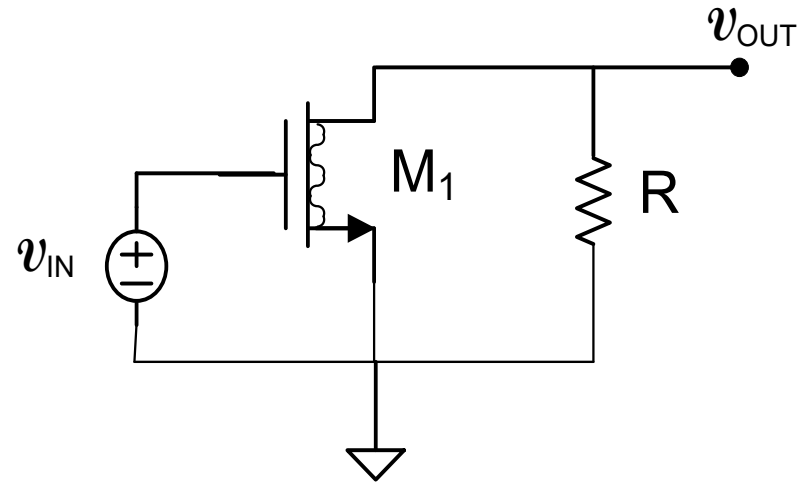

Linearized small-signal network





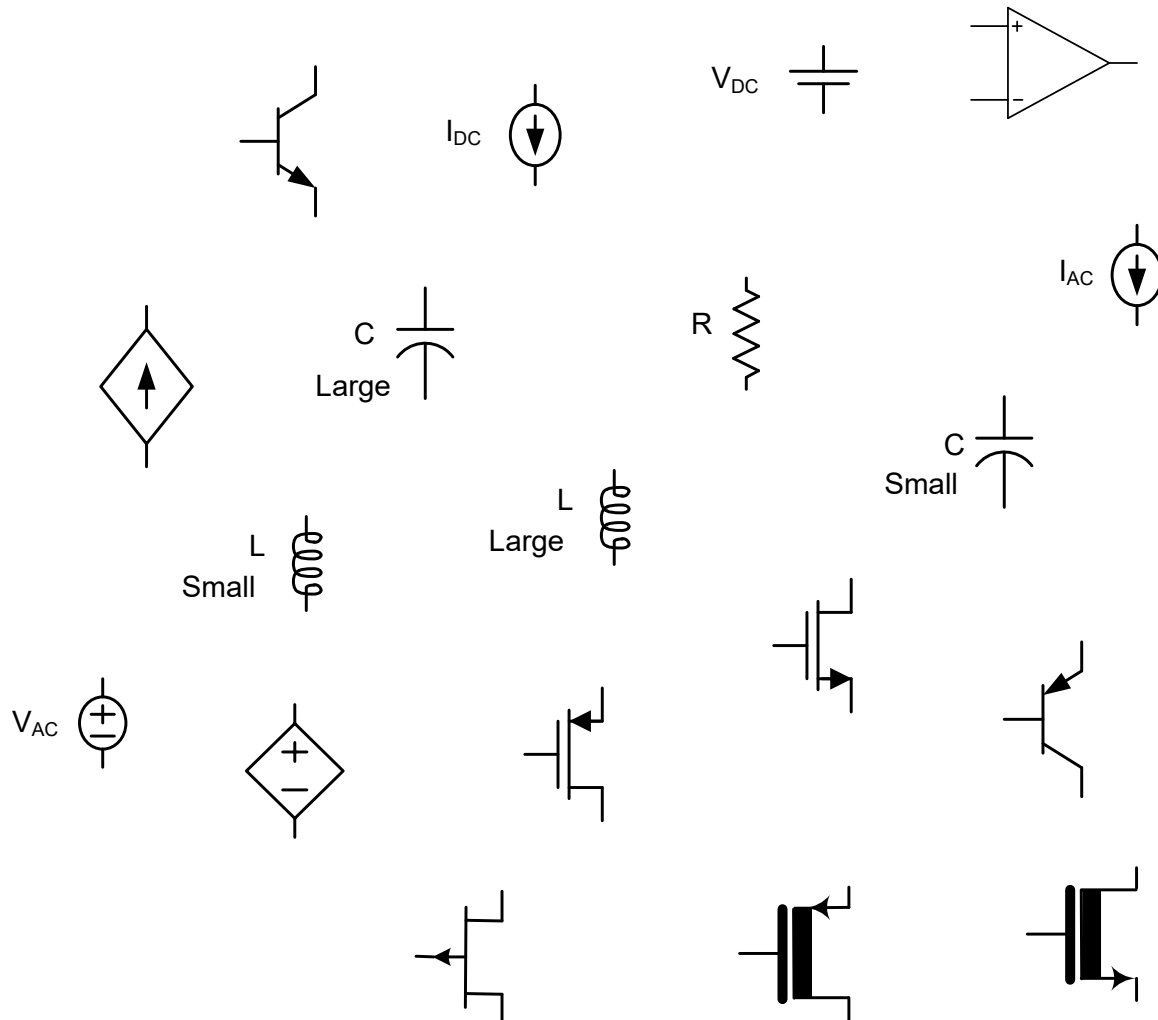









Linearized Small-Signal Circuit Elements

Must obtain the linearized small-signal circuit element for ALL linear and nonlinear circuit elements











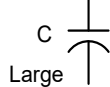

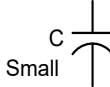



(Will also give models that are usually used for Q-point calculations : Simplified dc models)







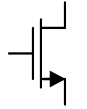
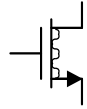
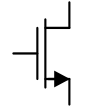
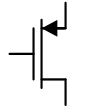
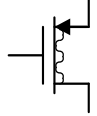
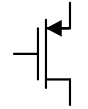

Small-signal and simplified dc equivalent elements

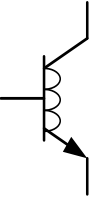
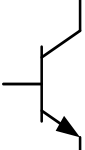
	Element	ss equivalent	Simplified dc equivalent
dc Voltage Source	V_{DC} 		V_{DC} 
ac Voltage Source	V_{AC} 	V_{AC} 	
dc Current Source	I_{DC} 		I_{DC} 
ac Current Source	I_{AC} 	I_{AC} 	
Resistor	R 	R 	R 

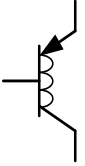
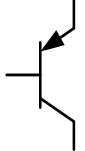
Small-signal and simplified dc equivalent elements

	Element	ss equivalent	Simplified dc equivalent
Capacitors	<p>C</p>  <p>Large</p>		
	<p>C</p>  <p>Small</p>		
Inductors	<p>L</p>  <p>Large</p>		
	<p>L</p>  <p>Small</p>		
Diodes			 <p>Simplified</p>
MOS transistors (MOSFET (enhancement or depletion), JFET)			 <p>Simplified</p>
			 <p>Simplified</p>

Small-signal and simplified dc equivalent elements

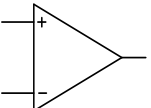
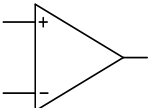
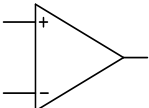
	Element	ss equivalent	Simplified dc equivalent
Bipolar Transistors			 Simplified
			 Simplified
Dependent Sources (Linear)			
	$V_O = A_V V_{IN}$ $I_O = A_I I_{IN}$ $V_O = R_T I_{IN}$ $I_O = G_T V_{IN}$		
			

Example: Obtain the small-signal equivalent circuit

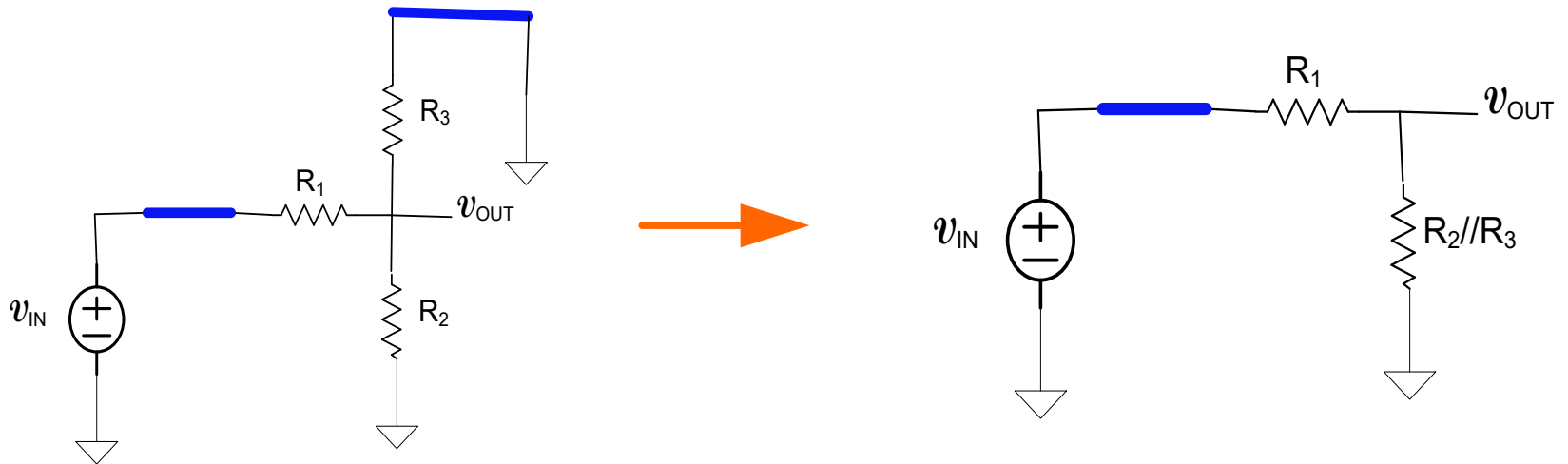
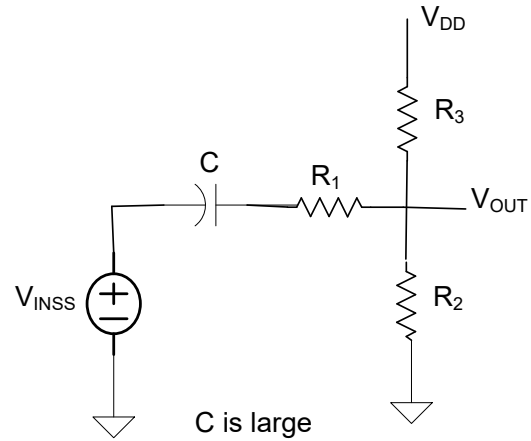

Example: Obtain the small-signal equivalent circuit

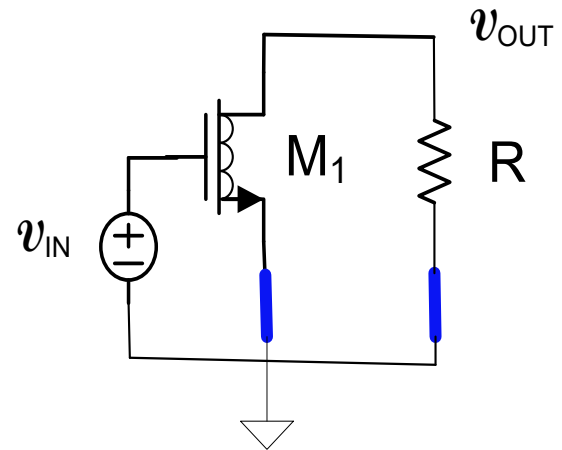
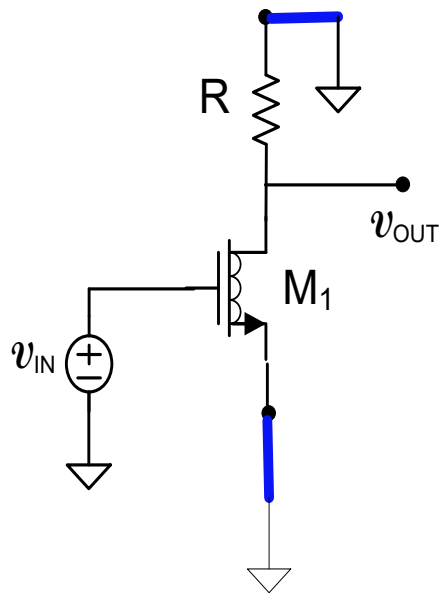
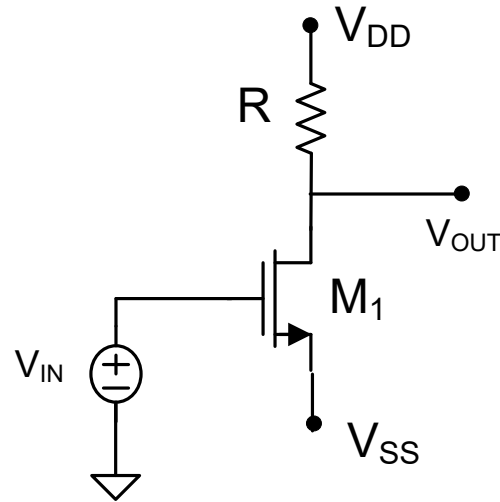

Example: Obtain the small-signal equivalent circuit

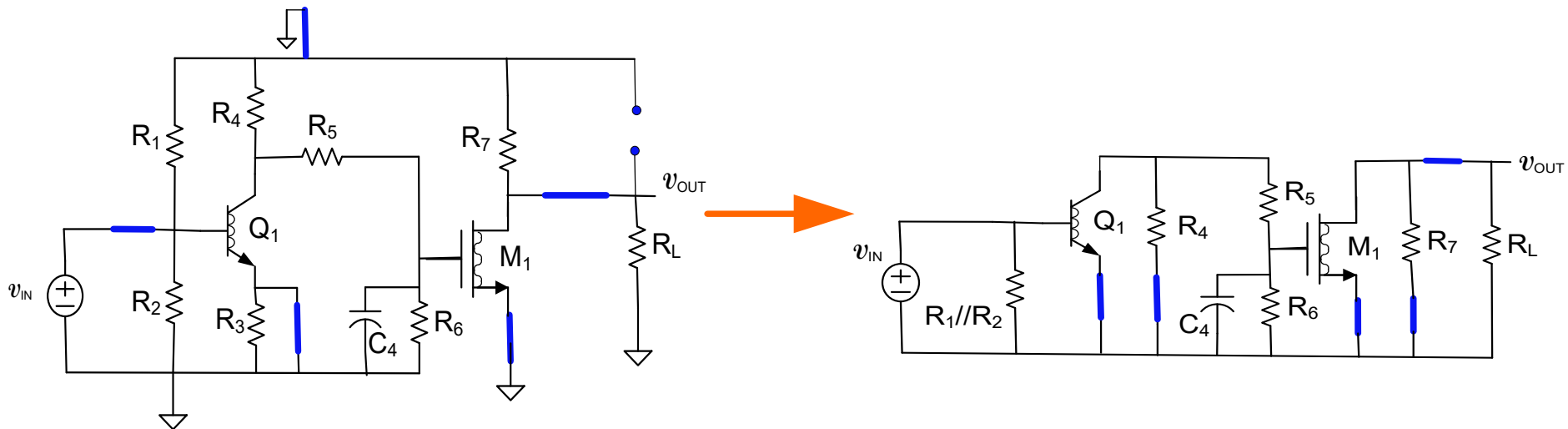
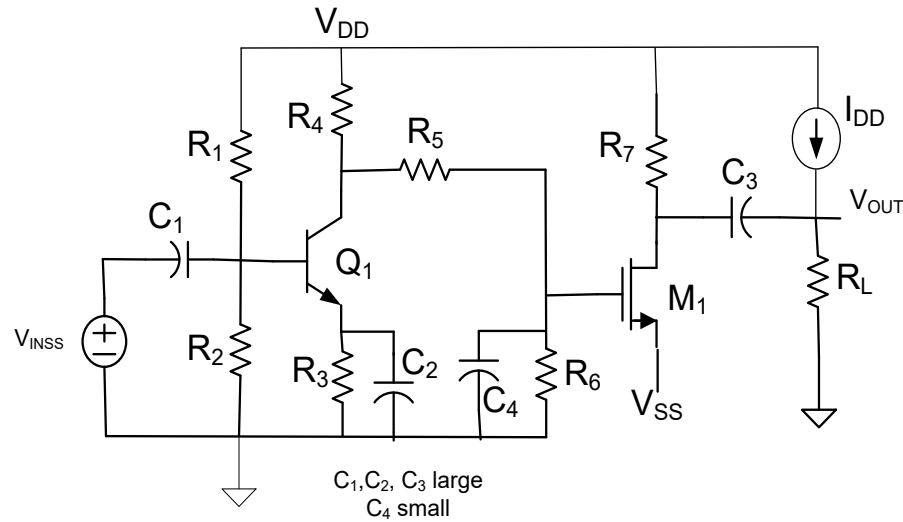

How is the small-signal equivalent circuit obtained from the nonlinear circuit?

What is the small-signal equivalent of the MOSFET, BJT, and diode ?

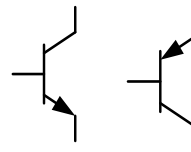
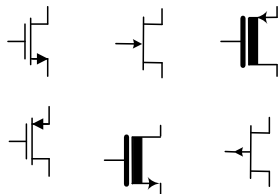
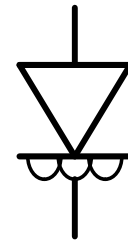
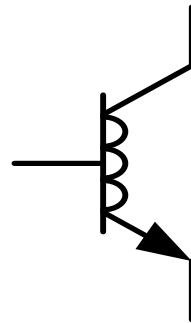
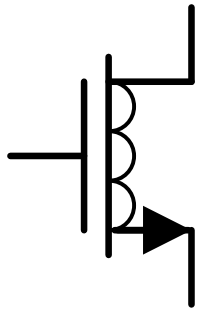

Small-Signal Diode Model

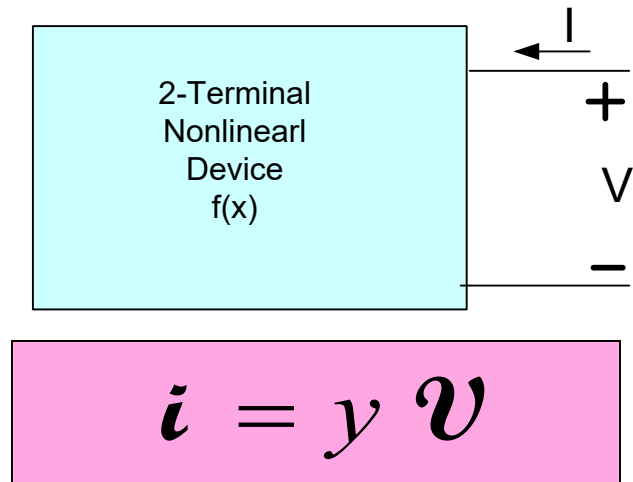

$$y = \left. \frac{\partial I}{\partial V} \right|_{V=V_Q}$$

A Small Signal Equivalent Circuit
"Small-signal model"

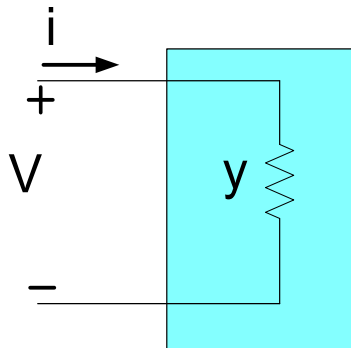

Thus, for the diode



Small-Signal Diode Model

For the diode



$$I_D = I_S e^{V_D / V_t}$$

$$y = \frac{\partial I_D}{\partial V_D} \Big|_Q = \left[\left(I_S e^{V_D / V_t} \right) \frac{1}{V_t} \right]_Q = \frac{I_{DQ}}{V_t} = \frac{1}{R_D}$$

$$R_d = \frac{V_t}{I_{DQ}}$$

Example of diode circuit where small-signal diode model is useful

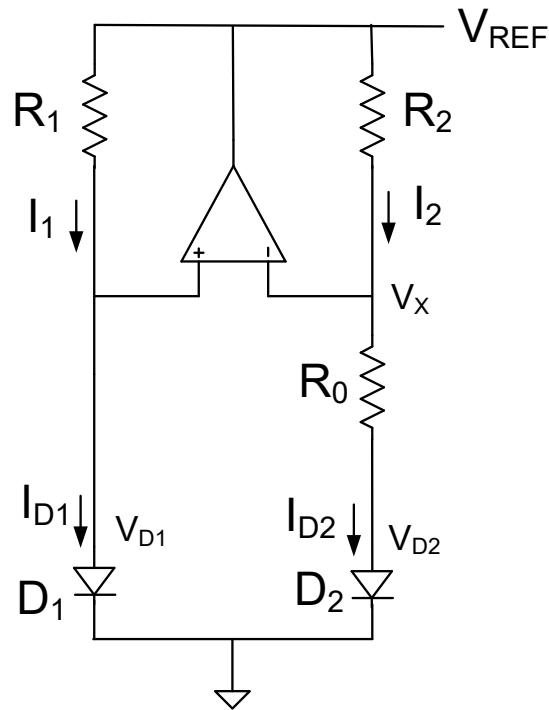

Voltage Reference

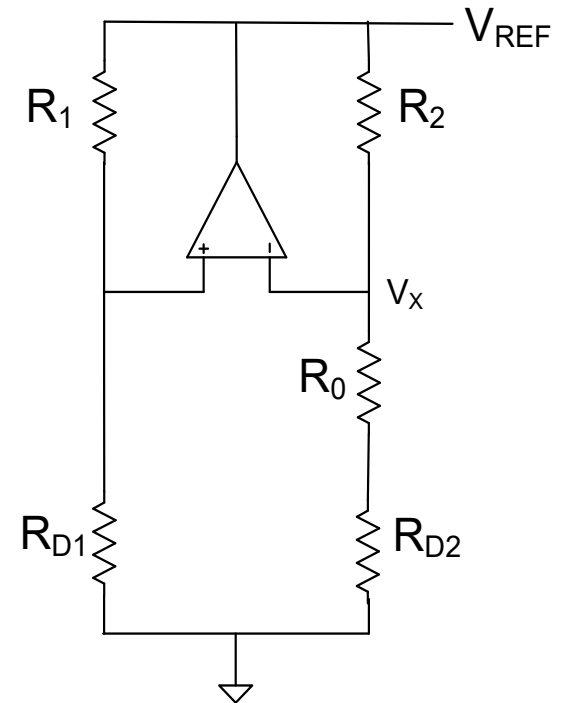

Small-signal model of Voltage Reference
(useful for compensation when parasitic Cs included)

Small-Signal Model of BJT and MOSFET

Consider 4-terminal network

(3-terminal and 2-terminal and 1-terminal devices then become special cases)

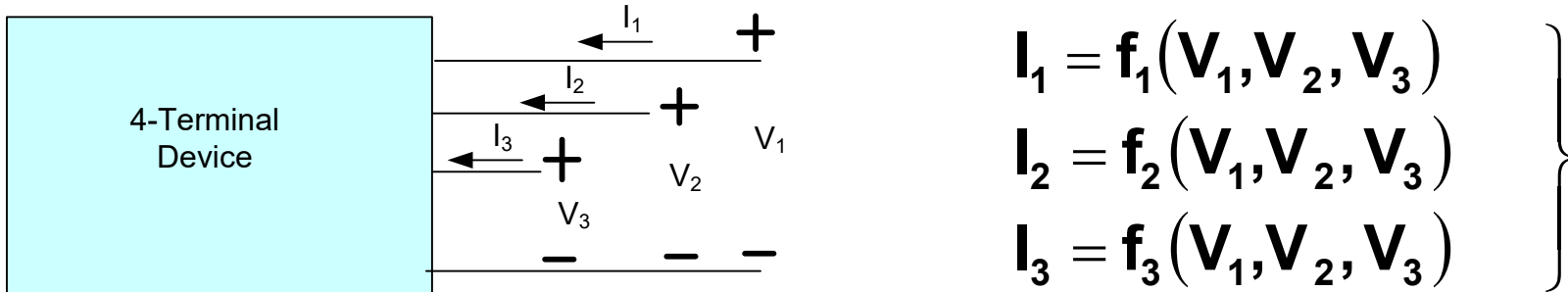

4 different ways to choose reference terminal

Six port electrical variables $\{I_1, I_2, I_3, V_1, V_2, V_3\}$

Number of ways to choose independent variables $\binom{6}{3} = \frac{6!}{(6-3)!3!} = 20$

Number of potentially different ways to represent same device 80

We will choose one of these 80 which uses port voltages as independent variables

Small-Signal Model of BJT and MOSFET

Consider 4-terminal network

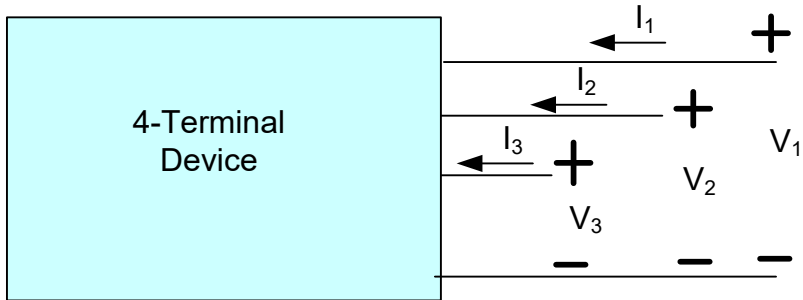

$$\left. \begin{aligned} I_1 &= f_1(V_1, V_2, V_3) \\ I_2 &= f_2(V_1, V_2, V_3) \\ I_3 &= f_3(V_1, V_2, V_3) \end{aligned} \right\}$$

Define

$$i_1 = I_1 - I_{1Q}$$

$$i_2 = I_2 - I_{2Q}$$

$$i_3 = I_3 - I_{3Q}$$

$$u_1 = V_1 - V_{1Q}$$

$$u_2 = V_2 - V_{2Q}$$

$$u_3 = V_3 - V_{3Q}$$

Small signal model is that which represents the relationship between the small signal voltages and the small signal currents

Small-Signal Model of 4-Terminal Network

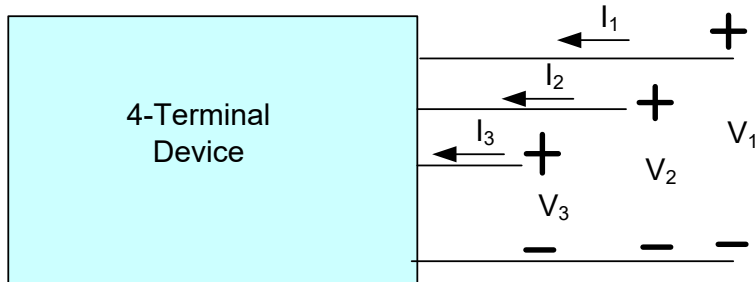

$$\left. \begin{aligned} i_1 &= g_1(v_1, v_2, v_3) \\ i_2 &= g_2(v_1, v_2, v_3) \\ i_3 &= g_3(v_1, v_2, v_3) \end{aligned} \right\}$$

Small signal model is that which represents the relationship between the small signal voltages and the small signal currents

For small signals, this relationship should be linear

Can be thought of as a change in coordinate systems from the large signal coordinate system to the small-signal coordinate system

Small-Signal Model of 4-Terminal Network

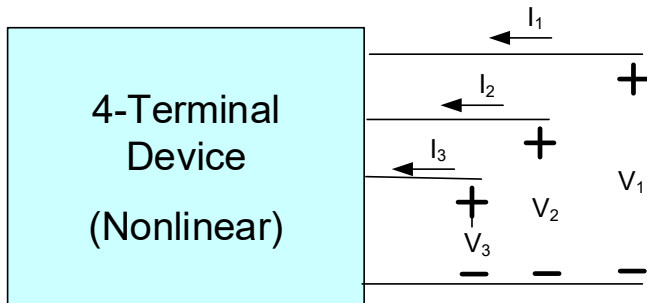

“Small-signal model”

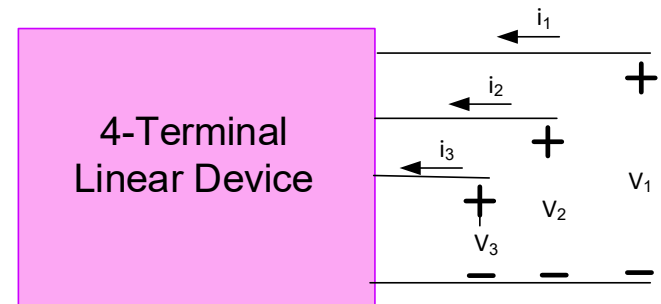

$$\left. \begin{aligned} I_1 &= f_1(V_1, V_2, V_3) \\ I_2 &= f_2(V_1, V_2, V_3) \\ I_3 &= f_3(V_1, V_2, V_3) \end{aligned} \right\}$$

$$\left. \begin{aligned} i_1 &= g_1(v_1, v_2, v_3) \\ i_2 &= g_2(v_1, v_2, v_3) \\ i_3 &= g_3(v_1, v_2, v_3) \end{aligned} \right\}$$

Mapping is unique (with same models)

Small-Signal Model of 4-Terminal Network

“Small-signal model”

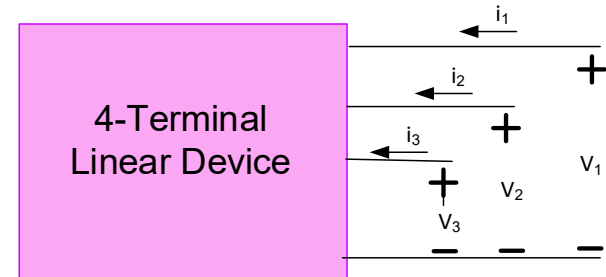
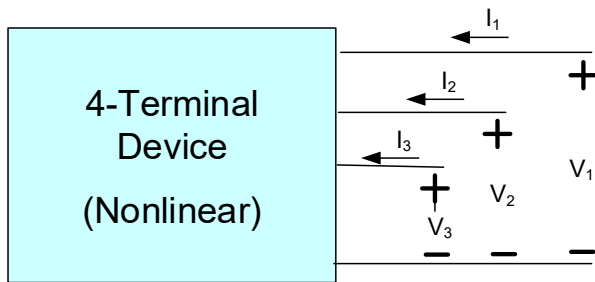

$$\left. \begin{aligned} I_1 &= f_1(V_1, V_2, V_3) \\ I_2 &= f_2(V_1, V_2, V_3) \\ I_3 &= f_3(V_1, V_2, V_3) \end{aligned} \right\}$$

$$\left. \begin{aligned} i_1 &= g_1(v_1, v_2, v_3) \\ i_2 &= g_2(v_1, v_2, v_3) \\ i_3 &= g_3(v_1, v_2, v_3) \end{aligned} \right\}$$

Does inverse mapping exist?

Yes

Is it unique (with same models)?

No

Multiple nonlinear circuits can have same small-signal circuit

Small-Signal Model of 4-Terminal Network

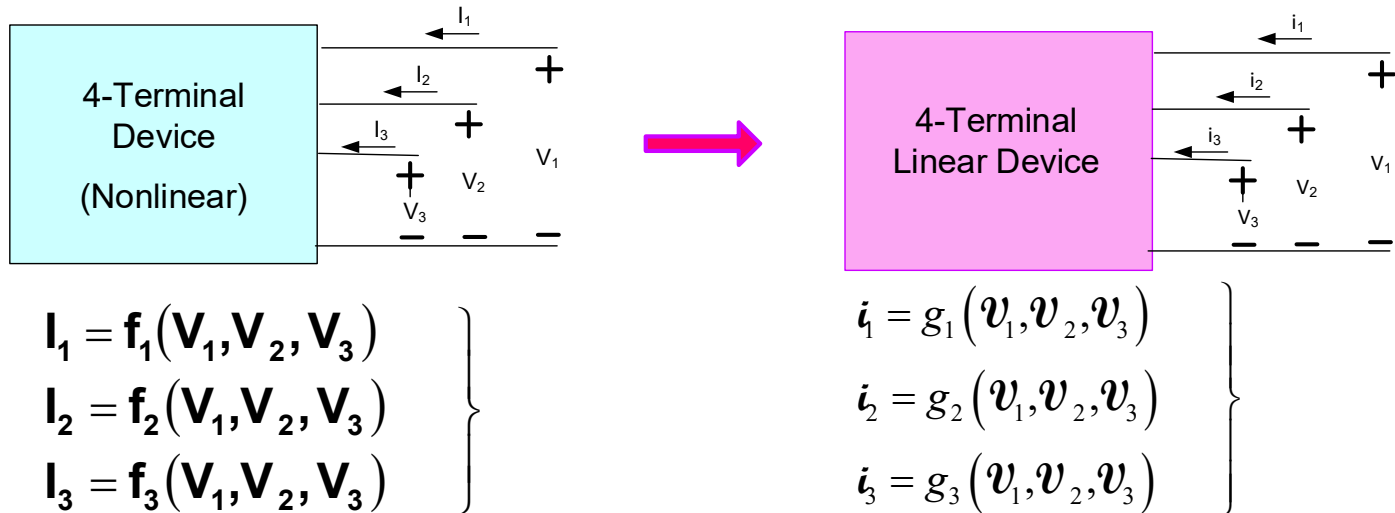

Systematic procedure for developing a small-signal model for any nonlinear device will now be developed

Will use 4-terminal device as an example and obtain results for 3-terminal and 2-terminal devices by inspection

Based upon multi-variate Taylor's series expansion truncated after first-order terms

Will then use this procedure to get small-signal model of Diode, MOSFET, BJT, and JFET

Recall for a function of one variable

$$y = f(x)$$

Taylor's Series Expansion about the point x_0 (x_0 is termed the expansion point or the Q-point)

$$y = f(x) = f(x)|_{x=x_0} + \left. \frac{\partial f}{\partial x} \right|_{x=x_0} (x - x_0) + \left. \frac{\partial^2 f}{\partial x^2} \right|_{x=x_0} \frac{1}{2!} (x - x_0)^2 + \dots$$

If $x-x_0$ is small

$$y \cong f(x)|_{x=x_0} + \left. \frac{\partial f}{\partial x} \right|_{x=x_0} (x - x_0)$$

$$y \cong y_0 + \left. \frac{\partial f}{\partial x} \right|_{x=x_0} (x - x_0)$$

Recall for a function of one variable

$$y = f(x)$$

If $x-x_0$ is small

$$y \cong y_0 + \left. \frac{\partial f}{\partial x} \right|_{x=x_0} (x - x_0)$$

$$y - y_0 = \left. \frac{\partial f}{\partial x} \right|_{x=x_0} (x - x_0)$$

If we define the small signal variables as

$$\boldsymbol{y} = y - y_0$$

$$\boldsymbol{x} = x - x_0$$

Recall for a function of one variable

$$y = f(x)$$

If $x-x_0$ is small

$$y \cong y_0 + \left. \frac{\partial f}{\partial x} \right|_{x=x_0} (x - x_0)$$

$$y - y_0 = \left. \frac{\partial f}{\partial x} \right|_{x=x_0} (x - x_0)$$

If we define the small signal variables as

$$\mathbf{y} = y - y_0$$

$$\mathbf{x} = x - x_0$$

Then

$$\mathbf{y} = \left. \frac{\partial f}{\partial x} \right|_{x=x_0} \cdot \mathbf{x}$$

This relationship is linear !

Consider now a function of n variables

$$y = f(x_1, \dots, x_n) = f(\vec{x})$$

If we consider an arbitrary expansion point $\vec{X}_0 = \{x_{10}, x_{20}, \dots, x_{n0}\}$

The multivariate Taylor's series expansion around the point \vec{X}_0 is given by

$$y = f(\vec{x}) = f(\mathbf{x}) \Big|_{\vec{x}=\vec{x}_0} + \sum_{k=1}^n \left(\frac{\partial f}{\partial \mathbf{x}_k} \Big|_{\vec{x}=\vec{x}_0} (\mathbf{x}_k - \mathbf{x}_{k0}) \right) + \sum_{\substack{k=1 \\ j=1}}^{n,n} \frac{\partial^2 f}{\partial \mathbf{x}_j \partial \mathbf{x}_k} \Big|_{\vec{x}=\vec{x}_0} \frac{1}{2!} (\mathbf{x}_j - \mathbf{x}_{j0})(\mathbf{x}_k - \mathbf{x}_{k0}) + \dots (\text{H.O.T.})$$

Truncating after first-order terms, we obtain the approximation

$$y - y_0 \cong \sum_{k=1}^n \left(\frac{\partial f}{\partial \mathbf{x}_k} \Big|_{\vec{x}=\vec{x}_0} (\mathbf{x}_k - \mathbf{x}_{k0}) \right)$$

where $y_0 = f(\mathbf{x}) \Big|_{\vec{x}=\vec{x}_0}$

Multivariate Taylors Series Expansion

$$y = f(x_1, \dots, x_n) = f(\vec{x})$$

Linearized approximation

$$y - y_0 \cong \sum_{k=1}^n \left(\frac{\partial f}{\partial x_k} \Big|_{\vec{x}=\vec{x}_0} (x_k - x_{k0}) \right)$$

This can be expressed as

$$y_{ss} \cong \sum_{k=1}^n a_k x_{ssk}$$

where

$$y_{ss} = y - y_0$$

$$x_{ssk} = x_k - x_{k0}$$

$$a_k = \frac{\partial f}{\partial x_k} \Big|_{\vec{x}=\vec{x}_0}$$

Alternate Notation:

$$\mathbf{y} \cong \sum_{k=1}^n a_k \mathbf{x}_k$$

$$\mathbf{y} = y - y_0$$

$$\mathbf{x}_k = x_k - x_{k0}$$

In the more general form¹, the multivariate Taylor's series expansion can be expressed as

$$f(x_1, \dots, x_n) = \alpha_o + \sum_{m=1}^{\infty} \left(\sum_{\substack{k_1, \dots, k_n \\ \left(\sum_j k_j = m \right)}} \alpha_{k_1, \dots, k_n; m} (x_1 - x_{1,o})^{k_1} \dots (x_n - x_{n,o})^{k_n} \right) \quad (7)$$

$$\alpha_o = f(x_{1o}, \dots, x_{no})$$

$$\alpha_{k_1, \dots, k_n; m} = \frac{1}{k_1! \dots k_n!} \frac{\partial^m f}{\partial^{k_1} x_1 \dots \partial^{k_n} x_n} \Big|_{x_{1o}, \dots, x_{no}} \quad (8)$$

¹ <http://www.chem.mtu.edu/~tbco/cm416/taylor.html>

Consider 4-terminal network

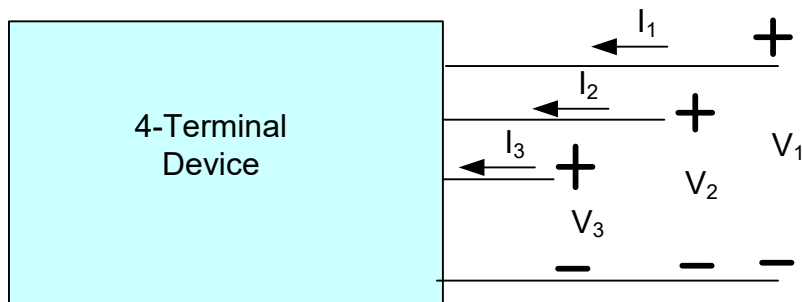

$$\left. \begin{aligned} \mathbf{I}_1 &= \mathbf{f}_1(\mathbf{V}_1, \mathbf{V}_2, \mathbf{V}_3) \\ \mathbf{I}_2 &= \mathbf{f}_2(\mathbf{V}_1, \mathbf{V}_2, \mathbf{V}_3) \\ \mathbf{I}_3 &= \mathbf{f}_3(\mathbf{V}_1, \mathbf{V}_2, \mathbf{V}_3) \end{aligned} \right\}$$

Nonlinear network characterized by 3 functions each functions of 3 variables

Consider now 3 functions each functions of 3 variables

$$\left. \begin{aligned} \mathbf{l}_1 &= \mathbf{f}_1(\mathbf{V}_1, \mathbf{V}_2, \mathbf{V}_3) \\ \mathbf{l}_2 &= \mathbf{f}_2(\mathbf{V}_1, \mathbf{V}_2, \mathbf{V}_3) \\ \mathbf{l}_3 &= \mathbf{f}_3(\mathbf{V}_1, \mathbf{V}_2, \mathbf{V}_3) \end{aligned} \right\}$$

Define

$$\vec{V}_Q = \begin{bmatrix} V_{1Q} \\ V_{2Q} \\ V_{3Q} \end{bmatrix}$$

In what follows, we will use \vec{V}_Q as an expansion point in a Taylor's series expansion.

Consider now 3 functions each functions of 3 variables

$$I_1 = f_1(\mathbf{V}_1, \mathbf{V}_2, \mathbf{V}_3)$$

$$I_2 = f_2(\mathbf{V}_1, \mathbf{V}_2, \mathbf{V}_3)$$

$$I_3 = f_3(\mathbf{V}_1, \mathbf{V}_2, \mathbf{V}_3)$$

Define

$$\vec{V}_Q = \begin{bmatrix} V_{1Q} \\ V_{2Q} \\ V_{3Q} \end{bmatrix}$$

Consider first the function I_1

The multivariate Taylors Series expansion of I_1 , around the operating point \vec{V}_Q . when truncated after first-order terms, can be expressed as:

$$I_1 = f_1(\mathbf{V}_1, \mathbf{V}_2, \mathbf{V}_3) \cong f_1(\mathbf{V}_{1Q}, \mathbf{V}_{2Q}, \mathbf{V}_{3Q}) + \left. \frac{\partial f_1(\mathbf{V}_1, \mathbf{V}_2, \mathbf{V}_3)}{\partial \mathbf{V}_1} \right|_{\vec{v}=\vec{v}_Q} (\mathbf{V}_1 - \mathbf{V}_{1Q}) + \left. \frac{\partial f_1(\mathbf{V}_1, \mathbf{V}_2, \mathbf{V}_3)}{\partial \mathbf{V}_2} \right|_{\vec{v}=\vec{v}_Q} (\mathbf{V}_2 - \mathbf{V}_{2Q}) + \left. \frac{\partial f_1(\mathbf{V}_1, \mathbf{V}_2, \mathbf{V}_3)}{\partial \mathbf{V}_3} \right|_{\vec{v}=\vec{v}_Q} (\mathbf{V}_3 - \mathbf{V}_{3Q})$$

or equivalently as:

$$I_1 - I_{1Q} = \left. \frac{\partial f_1(\mathbf{V}_1, \mathbf{V}_2, \mathbf{V}_3)}{\partial \mathbf{V}_1} \right|_{\vec{v}=\vec{v}_Q} (\mathbf{V}_1 - \mathbf{V}_{1Q}) + \left. \frac{\partial f_1(\mathbf{V}_1, \mathbf{V}_2, \mathbf{V}_3)}{\partial \mathbf{V}_2} \right|_{\vec{v}=\vec{v}_Q} (\mathbf{V}_2 - \mathbf{V}_{2Q}) + \left. \frac{\partial f_1(\mathbf{V}_1, \mathbf{V}_2, \mathbf{V}_3)}{\partial \mathbf{V}_3} \right|_{\vec{v}=\vec{v}_Q} (\mathbf{V}_3 - \mathbf{V}_{3Q})$$

repeating from previous slide:

$$I_1 - I_{1Q} = \left. \frac{\partial f_1(\mathbf{V}_1, \mathbf{V}_2, \mathbf{V}_3)}{\partial \mathbf{V}_1} \right|_{\bar{\mathbf{v}} = \bar{\mathbf{v}}_Q} (\mathbf{V}_1 - \mathbf{V}_{1Q}) + \left. \frac{\partial f_1(\mathbf{V}_1, \mathbf{V}_2, \mathbf{V}_3)}{\partial \mathbf{V}_2} \right|_{\bar{\mathbf{v}} = \bar{\mathbf{v}}_Q} (\mathbf{V}_2 - \mathbf{V}_{2Q}) + \left. \frac{\partial f_1(\mathbf{V}_1, \mathbf{V}_2, \mathbf{V}_3)}{\partial \mathbf{V}_3} \right|_{\bar{\mathbf{v}} = \bar{\mathbf{v}}_Q} (\mathbf{V}_3 - \mathbf{V}_{3Q})$$

Make the following definitions

$$y_{11} = \left. \frac{\partial f_1(\mathbf{V}_1, \mathbf{V}_2, \mathbf{V}_3)}{\partial \mathbf{V}_1} \right|_{\bar{\mathbf{v}} = \bar{\mathbf{v}}_Q}$$

$$y_{12} = \left. \frac{\partial f_1(\mathbf{V}_1, \mathbf{V}_2, \mathbf{V}_3)}{\partial \mathbf{V}_2} \right|_{\bar{\mathbf{v}} = \bar{\mathbf{v}}_Q}$$

$$y_{13} = \left. \frac{\partial f_1(\mathbf{V}_1, \mathbf{V}_2, \mathbf{V}_3)}{\partial \mathbf{V}_3} \right|_{\bar{\mathbf{v}} = \bar{\mathbf{v}}_Q}$$

$$i_1 = I_1 - I_{1Q}$$

$$i_2 = I_2 - I_{2Q}$$

$$i_3 = I_3 - I_{3Q}$$

$$u_1 = \mathbf{V}_1 - \mathbf{V}_{1Q}$$

$$u_2 = \mathbf{V}_2 - \mathbf{V}_{2Q}$$

$$u_3 = \mathbf{V}_3 - \mathbf{V}_{3Q}$$

It thus follows that

$$i_1 = y_{11} u_1 + y_{12} u_2 + y_{13} u_3$$

This is a linear relationship between the small signal electrical variables !

Small Signal Model Development

Nonlinear Model

Linear Model at $\bar{\mathbf{V}}_Q$
(alt. small signal model)

$$I_1 = \mathbf{f}_1(V_1, V_2, V_3) \quad \rightarrow \quad \dot{i}_1 = y_{11}u_1 + y_{12}u_2 + y_{13}u_3$$

$$I_2 = \mathbf{f}_2(V_1, V_2, V_3)$$

$$I_3 = \mathbf{f}_3(V_1, V_2, V_3)$$

Extending this approach to the two nonlinear functions I_2 and I_3

$$\dot{i}_2 = y_{21}u_1 + y_{22}u_2 + y_{23}u_3$$

$$\dot{i}_3 = y_{31}u_1 + y_{32}u_2 + y_{33}u_3$$

where

$$y_{ij} = \left. \frac{\partial \mathbf{f}_i(V_1, V_2, V_3)}{\partial V_j} \right|_{\bar{\mathbf{V}} = \bar{\mathbf{V}}_Q}$$

Small Signal Model Development

Nonlinear Model

$$I_1 = f_1(V_1, V_2, V_3)$$



$$I_2 = f_2(V_1, V_2, V_3)$$



$$I_3 = f_3(V_1, V_2, V_3)$$



Linear Model at \bar{V}_Q
(alt. small signal model)

$$i_1 = y_{11}u_1 + y_{12}u_2 + y_{13}u_3$$

$$i_2 = y_{21}u_1 + y_{22}u_2 + y_{23}u_3$$

$$i_3 = y_{31}u_1 + y_{32}u_2 + y_{33}u_3$$

where

$$y_{ij} = \left. \frac{\partial f_i(V_1, V_2, V_3)}{\partial V_j} \right|_{\bar{V}=\bar{V}_Q}$$

Small Signal Model

$$\dot{\mathbf{i}}_1 = y_{11}\mathbf{u}_1 + y_{12}\mathbf{u}_2 + y_{13}\mathbf{u}_3$$

$$\dot{\mathbf{i}}_2 = y_{21}\mathbf{u}_1 + y_{22}\mathbf{u}_2 + y_{23}\mathbf{u}_3$$

$$\dot{\mathbf{i}}_3 = y_{31}\mathbf{u}_1 + y_{32}\mathbf{u}_2 + y_{33}\mathbf{u}_3$$

where

$$\mathbf{y}_{ij} = \left. \frac{\partial \mathbf{f}_i(\mathbf{V}_1, \mathbf{V}_2, \mathbf{V}_3)}{\partial \mathbf{V}_j} \right|_{\bar{\mathbf{V}} = \bar{\mathbf{V}}_Q}$$

- This is a small-signal model of a 4-terminal network and it is linear
- 9 small-signal parameters characterize the linear 4-terminal network
- Small-signal model parameters dependent upon Q-point !
- Termed the y-parameter model or “admittance” –parameter model

A small-signal equivalent circuit of a 4-terminal nonlinear network (equivalent circuit because has exactly the same port equations)

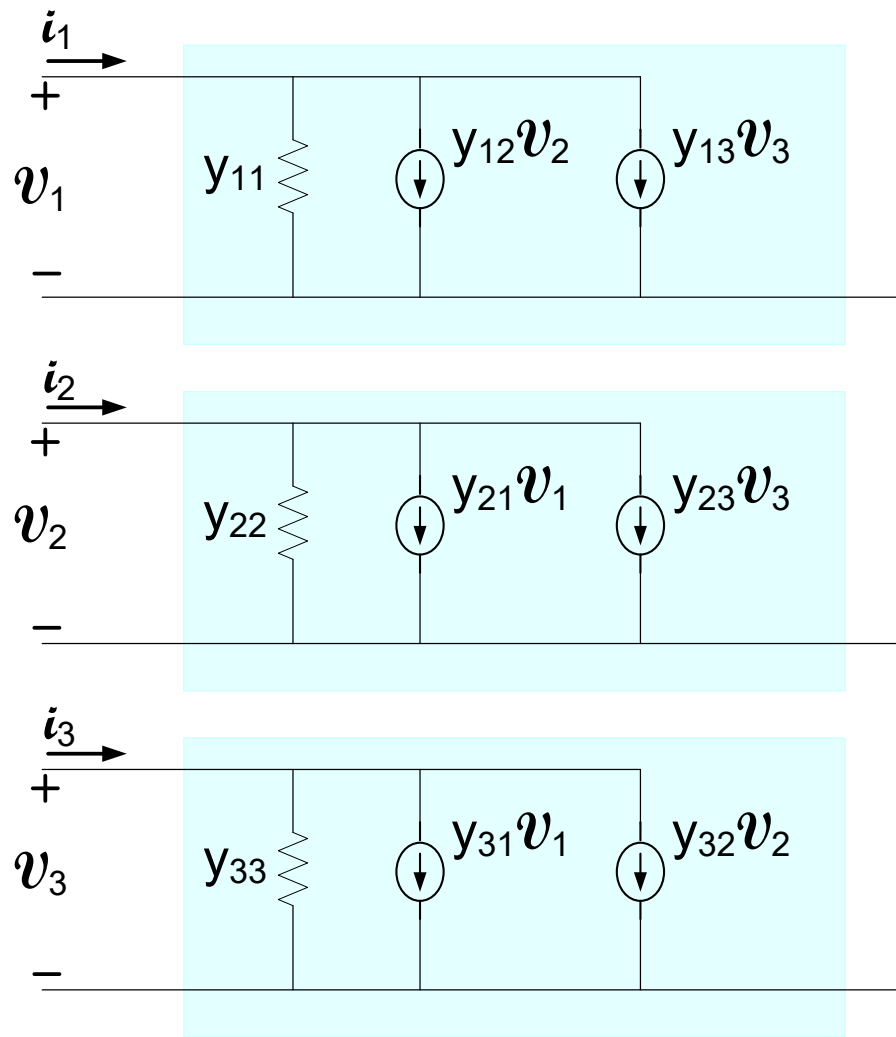

$$y_{ij} = \left. \frac{\partial f_i(\mathbf{V}_1, \mathbf{V}_2, \mathbf{V}_3)}{\partial \mathbf{V}_j} \right|_{\bar{\mathbf{V}} = \bar{\mathbf{V}}_Q}$$

Equivalent circuit is not unique
Equivalent circuit is a three-port network

4-terminal small-signal network summary

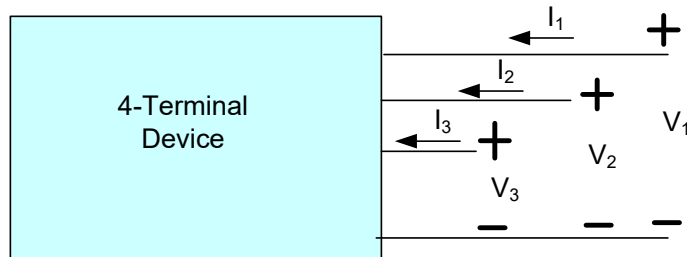

$$\left. \begin{aligned} \mathbf{I}_1 &= \mathbf{f}_1(\mathbf{V}_1, \mathbf{V}_2, \mathbf{V}_3) \\ \mathbf{I}_2 &= \mathbf{f}_2(\mathbf{V}_1, \mathbf{V}_2, \mathbf{V}_3) \\ \mathbf{I}_3 &= \mathbf{f}_3(\mathbf{V}_1, \mathbf{V}_2, \mathbf{V}_3) \end{aligned} \right\}$$

Small signal model:

$$\mathbf{i}_1 = y_{11}\mathbf{u}_1 + y_{12}\mathbf{u}_2 + y_{13}\mathbf{u}_3$$

$$\mathbf{i}_2 = y_{21}\mathbf{u}_1 + y_{22}\mathbf{u}_2 + y_{23}\mathbf{u}_3$$

$$\mathbf{i}_3 = y_{31}\mathbf{u}_1 + y_{32}\mathbf{u}_2 + y_{33}\mathbf{u}_3$$

$$\mathbf{y}_{ij} = \left. \frac{\partial \mathbf{f}_i(\mathbf{V}_1, \mathbf{V}_2, \mathbf{V}_3)}{\partial \mathbf{V}_j} \right|_{\bar{\mathbf{V}} = \bar{\mathbf{V}}_Q}$$

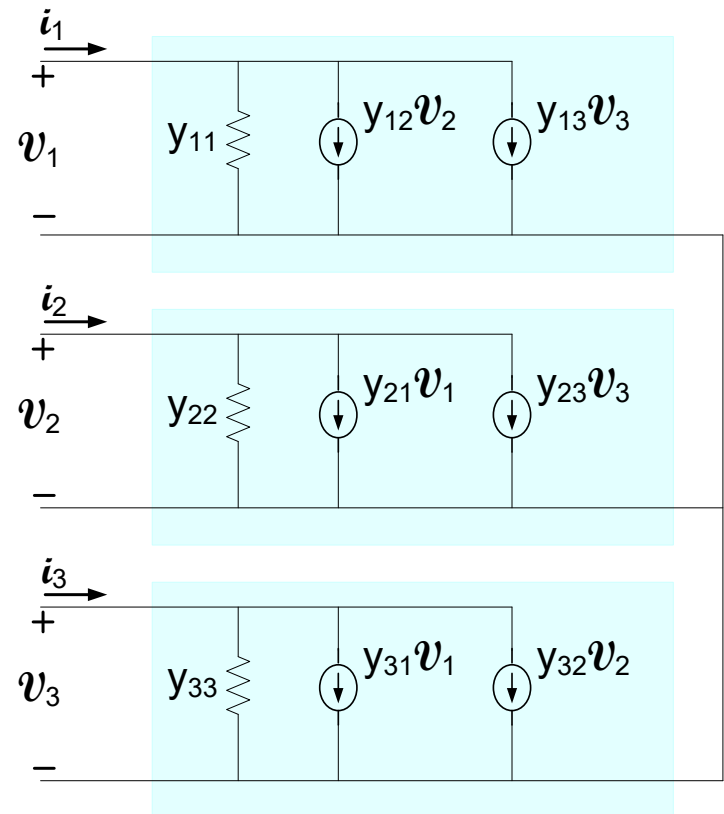

Consider 3-terminal network

Small-Signal Model

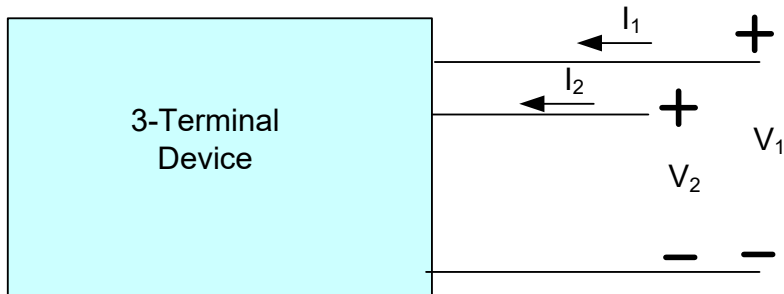

$$\left. \begin{aligned} I_1 &= f_1(\mathbf{V}_1, \mathbf{V}_2) \\ I_2 &= f_2(\mathbf{V}_1, \mathbf{V}_2) \end{aligned} \right\}$$

Define

$$i_1 = I_1 - I_{1Q}$$

$$u_1 = V_1 - V_{1Q}$$

$$i_2 = I_2 - I_{2Q}$$

$$u_2 = V_2 - V_{2Q}$$

Small signal model is that which represents the relationship between the small signal voltages and the small signal currents

Consider 3-terminal network

Small-Signal Model

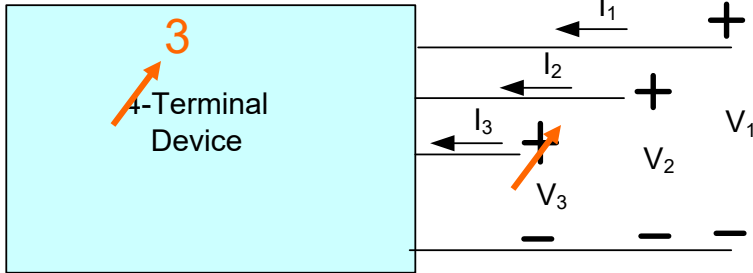

$$\left. \begin{aligned} \dot{i}_1 &= g_1(v_1, v_2, v_3) \\ \dot{i}_2 &= g_2(v_1, v_2, v_3) \\ \dot{i}_3 &= g_3(v_1, v_2, v_3) \end{aligned} \right\}$$

$$\dot{i}_1 = y_{11}v_1 + y_{12}v_2 + y_{13}v_3$$

$$\dot{i}_2 = y_{21}v_1 + y_{22}v_2 + y_{23}v_3$$

$$\dot{i}_3 = y_{31}v_1 + y_{32}v_2 + y_{33}v_3$$

$$y_{ij} = \left. \frac{\partial f_i(\mathbf{V}_1, \mathbf{V}_2, \mathbf{V}_3)}{\partial V_j} \right|_{\bar{\mathbf{v}} = \bar{\mathbf{v}}_Q}$$

Consider 3-terminal network

Small-Signal Model

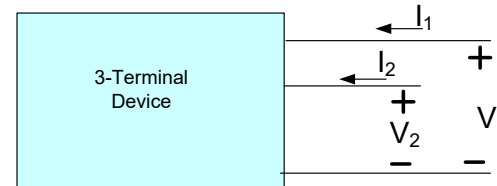

$$\begin{aligned} \dot{i}_1 &= y_{11} \mathbf{v}_1 + y_{12} \mathbf{v}_2 \\ \dot{i}_2 &= y_{21} \mathbf{v}_1 + y_{22} \mathbf{v}_2 \end{aligned}$$

$$y_{ij} = \left. \frac{\partial f_i(\mathbf{V}_1, \mathbf{V}_2)}{\partial \mathbf{V}_j} \right|_{\bar{\mathbf{v}} = \bar{\mathbf{v}}_Q}$$

$$\bar{\mathbf{V}} = \begin{pmatrix} \mathbf{V}_{1Q} \\ \mathbf{V}_{2Q} \end{pmatrix}$$

A Small Signal Equivalent Circuit (not unique)

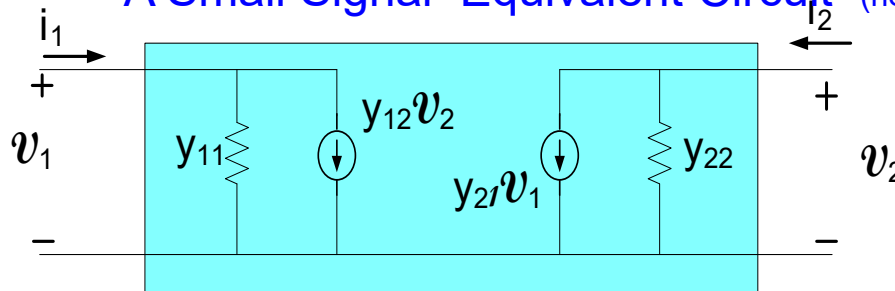

- *Small-signal model is a “two-port”*
- *4 small-signal parameters characterize this 3-terminal linear network*
- *Small signal parameters dependent upon Q-point*

3-terminal small-signal network summary

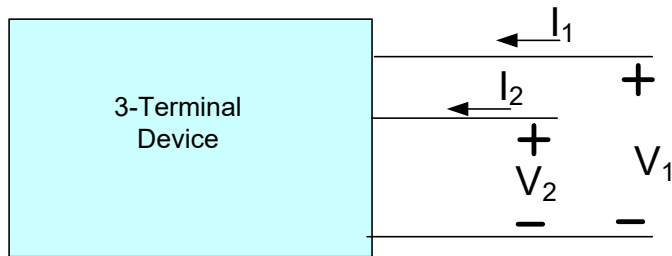

$$\left. \begin{aligned} \mathbf{I}_1 &= \mathbf{f}_1(\mathbf{V}_1, \mathbf{V}_2) \\ \mathbf{I}_2 &= \mathbf{f}_2(\mathbf{V}_1, \mathbf{V}_2) \end{aligned} \right\}$$

Small signal model:

$$\begin{aligned} \mathbf{i}_1 &= y_{11} \mathbf{v}_1 + y_{12} \mathbf{v}_2 \\ \mathbf{i}_2 &= y_{21} \mathbf{v}_1 + y_{22} \mathbf{v}_2 \end{aligned}$$

$$\mathbf{y}_{ij} = \left. \frac{\partial \mathbf{f}_i(\mathbf{V}_1, \mathbf{V}_2)}{\partial \mathbf{V}_j} \right|_{\bar{\mathbf{v}} = \bar{\mathbf{v}}_Q}$$

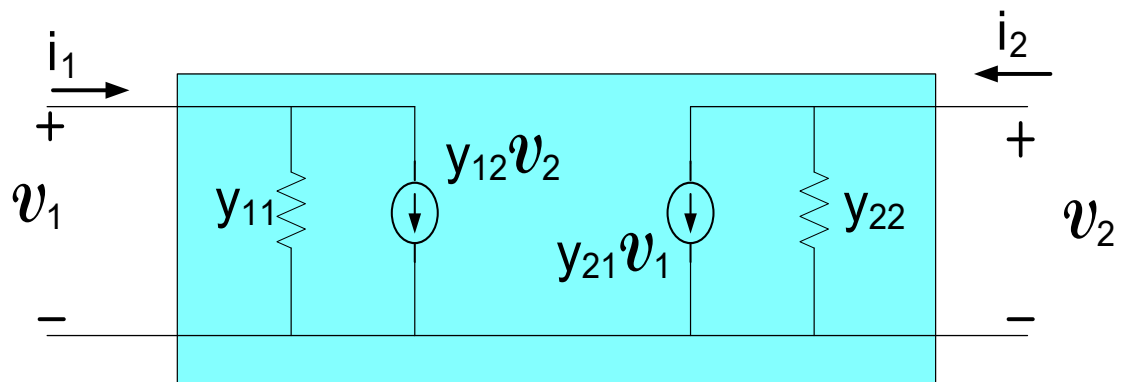

Consider 2-terminal network

Small-Signal Model

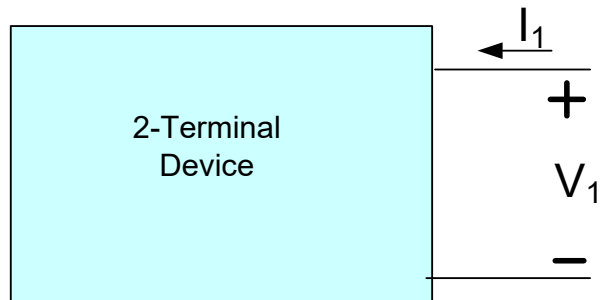

$$I_1 = f_1(V_1)$$

Define

$$i_1 = I_1 - I_{1Q}$$
$$v_1 = V_1 - V_{1Q}$$

Small signal model is that which represents the relationship between the small signal voltages and the small signal currents

Consider 2-terminal network

Small-Signal Model

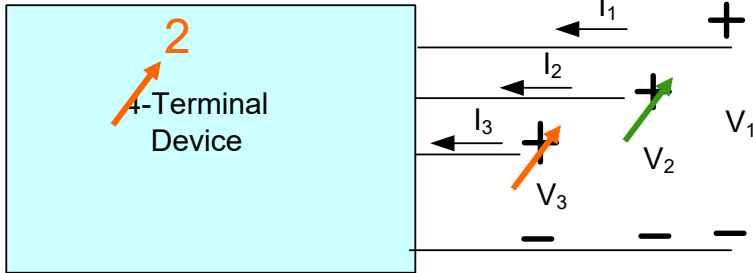

$$\left. \begin{aligned} \dot{i}_1 &= g_1(v_1, v_2, v_3) \\ \dot{i}_2 &= g_2(v_1, v_2, v_3) \\ \dot{i}_3 &= g_3(v_1, v_2, v_3) \end{aligned} \right\}$$

$$y_{ij} = \left. \frac{\partial f_i(\mathbf{V}_1, \mathbf{V}_2, \mathbf{V}_3)}{\partial \mathbf{V}_j} \right|_{\bar{\mathbf{v}} = \bar{\mathbf{v}}_Q}$$

$$\dot{i}_1 = y_{11}v_1 + y_{12}v_2 + y_{13}v_3$$

$$\dot{i}_2 = y_{21}v_1 + y_{22}v_2 + y_{23}v_3$$

$$\dot{i}_3 = y_{31}v_1 + y_{32}v_2 + y_{33}v_3$$

Small-Signal Model

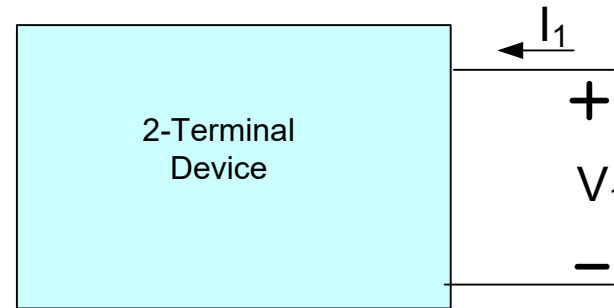

$$\mathbf{i}_1 = \mathbf{y}_{11} \mathbf{v}_1$$

$$\mathbf{y}_{11} = \left. \frac{\partial \mathbf{f}_1(V_1)}{\partial V_1} \right|_{\bar{V} = \bar{V}_Q} \quad \bar{V} = V_{1Q}$$

A Small Signal Equivalent Circuit

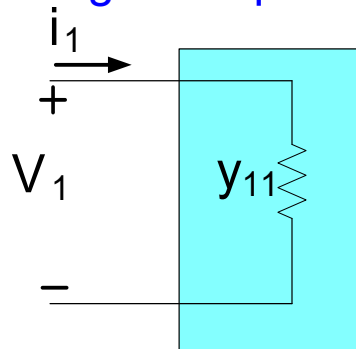

Small-signal model is a one-port

This was actually developed earlier !

Linearized nonlinear devices

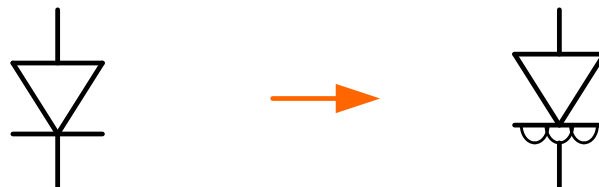
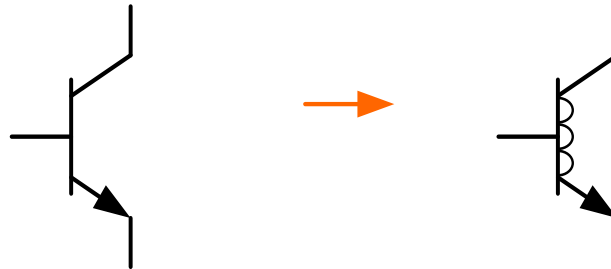
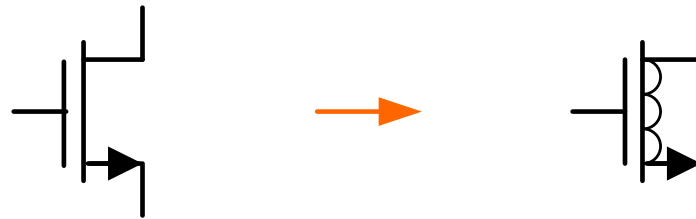
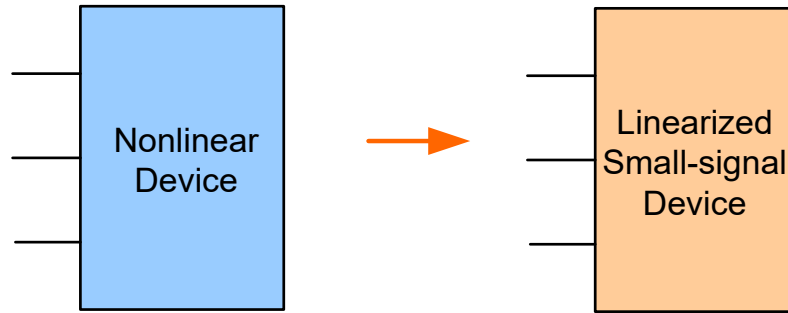

How is the small-signal equivalent circuit obtained from the nonlinear circuit?

What is the small-signal equivalent of the MOSFET, BJT, and diode ?

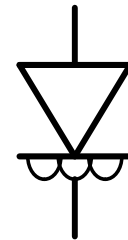
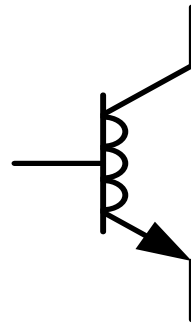
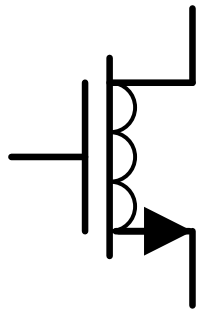



Stay Safe and Stay Healthy !

End of Lecture 24